

Ball Splines

One End Stepped

One End Stepped



RoHS10

One End Stepped	Spline Shaft / 52100 Bearing Steel Nut 4115 Alloy Steel Equivalent / Hardness: 58HRC min.		Spline Shaft, Nut / 440C Stainless Steel Equivalent / Hardness: 55 HRC min.
	Nut 1 pc.	Nut 2 pcs.	Nut 1 pc.
With Round Flange Nut	BSDM	BSD2M	BSDMS
With Compact Flange Nut	BSDN	BSD2N	
With Straight Nut	BSDS	BSD2S	BSDSS

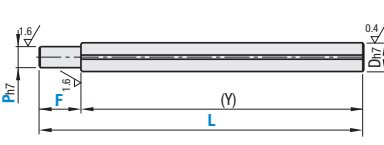

① When selecting Overall Length (L Dimension), check the Annealing Range. **P.409**
 ② Accuracy **P.407**
 ③ Choose Accessories Nuts from the following Shapes.

Flanged Nut Orientation

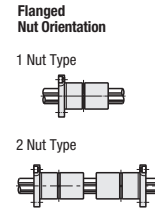

Round Flange Nuts

No. 6, 8 (3-d Oil Hole)
 No. 10, 13 (4-d Oil Hole)
 No. 16, 20, 25, 30 (5-d Oil Hole)

Compact Flange Nuts

No. 6, 8 (2-Mounting Holes, 3-d Oil Hole)
 No. 10 (2-Mounting Holes, 4-d Oil Hole)

Straight Nuts

No. 6, 8 (3-d Oil Hole)
 No. 10, 13 (4-d Oil Hole)
 No. 16, 20, 25, 30 (5-d Oil Hole)

Dimension of Attached Key

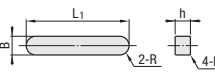

* The key is press-fit into the nut.

Part Number		1mm Increment			F	P	D	(Y)		Mass (kg/m)
Type	No.	L		1-Nut Type min-max				2-Nut Type min-max		
BSDM	*6	60-400 (190)	60-400	3				4 5	6	
BSDN	*8	60-400 (190)	60-400	4	5 6	8	58-398 (188)	58-398	0.39	
BSDS	*10	60-600 (390)	90-600	4	5 6 8	10.4	58-598 (388)	88-598	0.65	
BSD2M	*13	60-600 (390)	100-600	5	6 8 10	13.4	58-598 (388)	98-598	1.11	
BSD2N	*16	70-600 (390)	110-600	5	6 8 10 12 13	16.6	68-598 (388)	108-598	1.65	
BSD2S	20	80-700	130-700	8	10 12 13 15 16	20.6	78-898	128-698	2.57	
BSDMS	25	90-900	150-900	8	10 12 13 15 16 20	25.8	88-898	148-898	4.04	
BSDSS	30	100-1150	170-1150	10	12 13 15 16 20 25	30.8	98-1148	168-1148	5.85	

① For BSDSS and BSDMS, only *marked sizes are available, and the Max. L and Y dimensions are in ().
 ② For BSDN and BSD2N, only No. 6, 8 and 10 are available.

No.	D (h6)	L	Df	H	P.C.D.	d ₁	d ₂	h	W	d	B	Basic Rated Torque		Basic Load Rating		Allowable Static Moment		Mass (kg)
												Dynamic C _r (N-m)	Static C _{st} (N-m)	Dynamic C (kN)	Static C ₀ (kN)	M ₀₁ (N-m)	M ₀₂ (N-m)	
6	14	25	30	6	22	3.5	6	3.1	6.5	1.5	18	3.8	7	1.2	2.1	5	36	0.03
8	16	32	32	6	24	3.5	6	3.1	6.5	1.5	21	4.8	8.7	1.2	2.1	5	36	0.04
10	21	40 (33)	42 (41)	6 (8)	32 (30)	4.5	8	4.4 (5.3)	14 (8.5)	1.5	25	19 (11)	34 (21)	3.8 (2.4)	6.9 (4.3)	26 (15)	181 (102)	0.09
13	24	44 (36)	44 (45)	7 (8)	33 (34)	4.5	8	4.4 (5.3)	15 (10)	1.5	28	28 (20)	52 (37)	4.6 (3.3)	8.3 (5.9)	36 (22)	251 (148)	0.11
16	31	50	51	7	40	4.5	8	4.4	18	2	31	51	93	6.2	11.1	56	386	0.2
20	35	63	58	9	45	5.5	9.5	5.4	22.5	2	35	85	154	8.5	15.3	83	611	0.3
25	42	71	65	9	52	5.5	9.5	5.4	26.5	2	42	193	348	15.4	27.7	173	1248	0.4
30	47	80	75	10	60	6.6	11	6.5	30	2.5	47	272	490	18.5	33.3	212	1581	0.57

① Dimensions in () are for 440C Stainless Steel. ② Allowable static moment M₀₁ is a value measured when a single nut is used, and M₀₂ is a value measured when two nuts are used.

No.	D (h6)	L	b	Tolerance	t +0.05 0	d	α	Basic Rated Torque		Basic Load Rating		Allowable Static Moment		Mass (kg)	Dimension of Key (Included)					
								Dynamic C _r (N-m)	Static C _{st} (N-m)	Dynamic C (kN)	Static C ₀ (kN)	M ₀₁ (N-m)	M ₀₂ (N-m)		B	Tolerance	h	Tolerance	L ₁	R
6	14	25	2.5	+0.014	1.2	1.5	15°	3.8	7	1.2	2.1	5	36	0.012	2.5	0	10.5	1.25		
8	16	32	3	0	1.5	1.5	25°	4.8	8.7	1.2	2.1	5	36	0.013	2.5	0	10.5	1.25		
10	21	40 (33)	3	0	1.5	1.5	15°	19 (11)	34 (21)	3.8 (2.4)	6.9 (4.3)	26 (15)	181 (102)	0.06	3	+0.016	3	-0.025	17 (14)	1.5
13	24	44 (36)	3	0	1.5	1.5	15°	28 (20)	52 (37)	4.6 (3.3)	8.3 (5.9)	36 (22)	251 (148)	0.07	3	+0.006	3	-0.025	17 (14)	1.5
16	31	50	3.5	0	2	2	15°	51	93	6.2	11.1	56	386	0.15	3.5	+0.024	3.5	0	18	1.75
20	35	63	4	0	2.5	2	15°	85	154	8.5	15.3	83	611	0.2	4	+0.012	4	-0.030	29	2
25	42	71	4	0	2.5	2	15°	193	348	15.4	27.7	173	1248	0.29	4	+0.012	4	-0.030	33	2
30	47	80	4	0	2.5	2	15°	272	490	18.5	33.3	212	1581	0.37	4	+0.012	4	-0.030	42	2

① Dimensions in () are for 440C Stainless Steel. ② Allowable static moment M₀₁ is a value measured when a single nut is used, and M₀₂ is a value measured when two nuts are used.

Ball Splines

One End Stepped, continued

Part Number Alterations

BSDN10 - 300 - F20 - P8 - SC15

Alterations	Wrench Flats	Set Screw Flat	Keyway on Shaft End	Retaining Ring Groove	Tapping																																																															
Code	SC	FC	PKC	TA	MC																																																															
Spec.	Adds a wrench flat. SC=1mm Increment SC+L ₁ ≤Y <table border="1"> <tr><td>No.</td><td>W</td><td>L₁</td></tr> <tr><td>6</td><td>5</td><td>8</td></tr> <tr><td>8</td><td>7</td><td>8</td></tr> <tr><td>10</td><td>8</td><td>8</td></tr> <tr><td>13</td><td>11</td><td>10</td></tr> <tr><td>16</td><td>14</td><td>10</td></tr> <tr><td>20</td><td>17</td><td>15</td></tr> <tr><td>25</td><td>22</td><td>15</td></tr> <tr><td>30</td><td>27</td><td>15</td></tr> </table>	No.	W	L ₁	6	5	8	8	7	8	10	8	8	13	11	10	16	14	10	20	17	15	25	22	15	30	27	15	Adds a set screw flat. Ordering Code: FC10-A8 FC, A=1mm Increment FC≤3xD ① When 1.5xD<FC, FC≤Y/2 ① A=0 or A≥2 <table border="1"> <tr><td>No.</td><td>h</td></tr> <tr><td>6</td><td>8</td></tr> <tr><td>8</td><td>8</td></tr> <tr><td>10</td><td>10</td></tr> <tr><td>13</td><td>13</td></tr> <tr><td>16</td><td>16</td></tr> <tr><td>20</td><td>20</td></tr> <tr><td>25</td><td>25</td></tr> <tr><td>30</td><td>30</td></tr> </table>	No.	h	6	8	8	8	10	10	13	13	16	16	20	20	25	25	30	30	Adds a keyway on the shaft end P. Ordering Code: PKC10 ① P≥8 ① PKC=1mm Increment ① PKC≤Px3 ① PKC≤F-1 ① Keyway Details P.408	Adds retaining ring grooves. Ordering Code: TA10 TA=1mm Increment ① P≥6 ① 4≤TA<F/2 ① For Retaining Ring Groove Details P.408	Machines tapped hole on the right end face. <table border="1"> <tr><td>No.</td><td>M</td></tr> <tr><td>6</td><td>3</td></tr> <tr><td>8</td><td>3, 4</td></tr> <tr><td>10</td><td>3, 4, 5</td></tr> <tr><td>13</td><td>5, 6</td></tr> <tr><td>16</td><td>6, 8</td></tr> <tr><td>20</td><td>6, 8, 10</td></tr> <tr><td>25</td><td>6, 8, 10, 12</td></tr> <tr><td>30</td><td>6, 10, 12</td></tr> </table>	No.	M	6	3	8	3, 4	10	3, 4, 5	13	5, 6	16	6, 8	20	6, 8, 10	25	6, 8, 10, 12	30	6, 10, 12
No.	W	L ₁																																																																		
6	5	8																																																																		
8	7	8																																																																		
10	8	8																																																																		
13	11	10																																																																		
16	14	10																																																																		
20	17	15																																																																		
25	22	15																																																																		
30	27	15																																																																		
No.	h																																																																			
6	8																																																																			
8	8																																																																			
10	10																																																																			
13	13																																																																			
16	16																																																																			
20	20																																																																			
25	25																																																																			
30	30																																																																			
No.	M																																																																			
6	3																																																																			
8	3, 4																																																																			
10	3, 4, 5																																																																			
13	5, 6																																																																			
16	6, 8																																																																			
20	6, 8, 10																																																																			
25	6, 8, 10, 12																																																																			
30	6, 10, 12																																																																			

① When selecting multiple alteration additions, more than 2 mm is needed between each feature to be added. Orientation between wrench flats or set screw flats to the spline nut keyway or flange counterbores are random and cannot be specified.

Part Number Example

BSDN10 - 300 - F20 - P6
BSDN10G - 300 - F20 - P6
BSDN10L - 300 - F20 - P6

① Alternative grease types available.

Part Number	L	F	P
BSDN10	300	F20	P6
BSDN10G	300	F20	P6
BSDN10L	300	F20	P6

Cautions for Ball Spline

Lubrication
 Ball splines are shipped greased. Reapply lubrication with Lithium soap based grease (Alvania Grease S2 by Showa Shell Sekiyu K.K), etc. as needed.

Tolerance for Mating Bores
 An H7 tolerance is recommended for mating bores for the spline nuts.

Nut Removal
 Balls do not fall out when the spline shaft is pulled out. Once the nuts are removed from the spline shaft, reassemble the ball spline while confirming match No.'s, character orientations, and positional relationship of these parts.

Nuts and shafts are offered as the set product. Thus, when using multiple pcs. of them, do not change the default combination.

Adding Nuts
 The ball spline ensures clearance and accuracy by integrating the nuts and shaft into one set. Thus, the nuts or shafts are not sold as separate items. When two nuts are required, select the 2-nut type part number.

