



Flat Belt Conveyor GV Series

Head Drive, 2-Groove Frame (Pulley Dia. 30 mm)

Conveyor Resource Site:
<http://www.misumiusa.com/conveyor/>
 The above site can be used to search for conveyor components and their maintenance parts.

■ Features: The drive section is more compact in comparison to CVGA. Most widely used standard head drive conveyor that can also be incorporated inside equipment.



*Taiwanese Motors are not RoHS compliant.

GVHA

- Each slot has 4 nuts inserted.
- The dimensions in the diagram is for Belt Specification H (which has a belt thickness of 0.9mm). Note that the belt thickness varies depending on belt specifications.
- When L>1,400, it is recommended to mount on at least 2 stands.

	Frame	Motor Cover	Pulley Holder
M Material	Aluminum	Aluminum	Aluminum
S Surface Treatment	Clear Anodize	Painted	Painted

6 W Motor Type

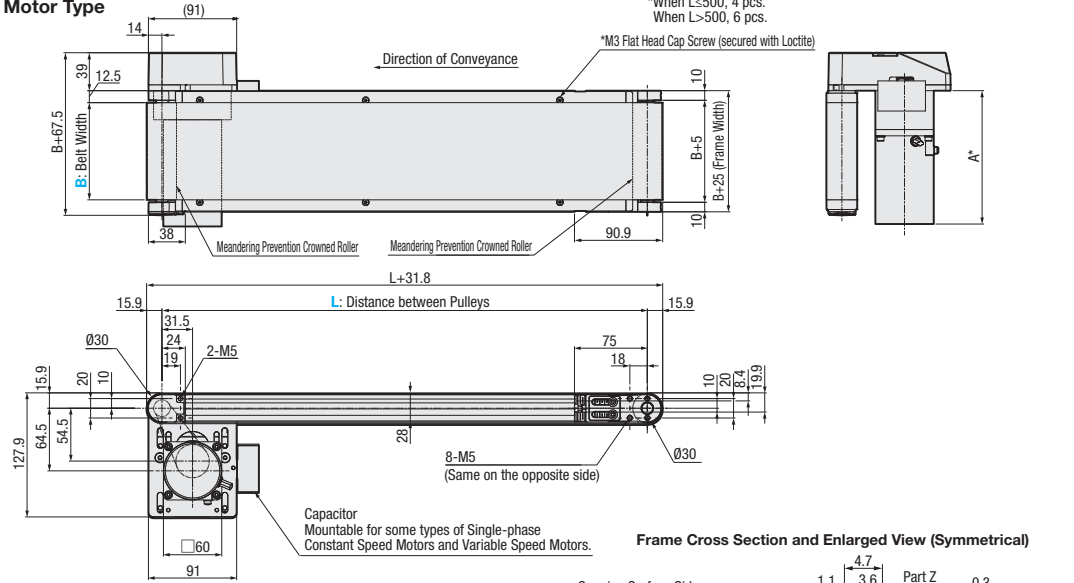

*When L<500, 4 pcs.
When L>500, 6 pcs.

*M3 Flat Head Cap Screw (secured with Loctite)

25 W Motor Type

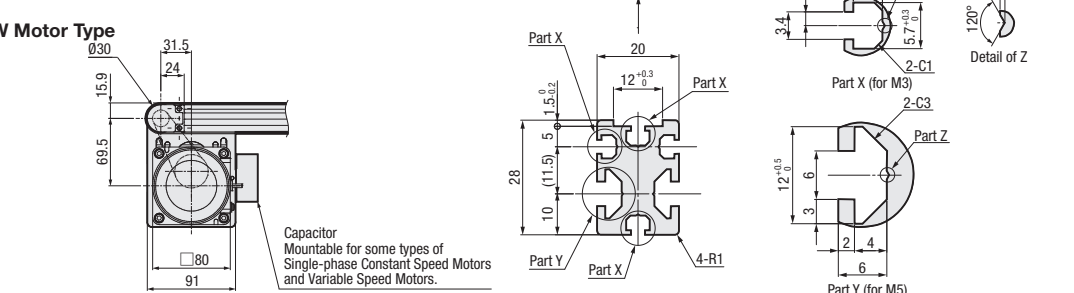

Capacitor Mountable for some types of Single-phase Constant Speed Motors and Variable Speed Motors.

***A Dimension (Motor Overall Length) Details**

Output (W)	Motor Specifications	Manufacturer	Reduction Ratio	A
6 W	Constant speed motor	Oriental	25-180	115.0
		Taiwanese	25-75	114.7
	Variable speed motor	Oriental	90-180	120.7
		Oriental	25-180	125.0
		Taiwanese	25-75	126.9
		Taiwanese	90-180	132.9
25 W	Constant speed motor	Panasonic	5-180	115.0
		Oriental	5-18	117.0
	Variable speed motor	Oriental	25-180	127.5
		Taiwanese	5-75	129.0
		Taiwanese	90-180	136.0
		Oriental	5-18	127.0
Variable speed motor	Oriental	25-180	137.5	
	Taiwanese	5-75	139.5	
	Taiwanese	90-180	146.5	

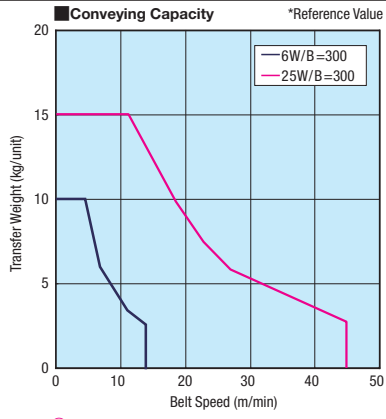

Gearhead Reduction Ratio *Reference Value

*Conveyance speed reference values are based on IM (motor rotational speed 1,500 rpm [50 Hz]/1,800 rpm [60 Hz]).
*May decrease depending on load condition.

Gearhead Reduction Ratio	Belt Speed (m/min)	
	50Hz	60Hz
5	56.4	67.7
7.5	37.6	45.1
9	31.3	37.6
12.5	22.6	27.1
15	18.8	22.6
18	15.7	18.8
25	11.3	13.5
30	9.4	11.3
36	7.8	9.4
50	5.6	6.8
60	4.7	5.6
75	3.8	4.5
90	3.1	3.8
100	2.8	3.4
120	2.4	2.8
150	1.9	2.3
180	1.6	1.9

- For motor specification IM, the above conveyance speeds are constant speeds.
- For motor specification SCM, refer to the above values for the maximum speed.
- Motor specification SCM is adjustable up to (1/15) × (max. speed). The weight that can be conveyed decreases as speed decreases.

Part Number	B 10 mm Increments	L 5 mm Increments	Motor				Belt Specifications	Motor Manufacturer Selection
			Output (W)	Voltage (V)	Specifications	Gearhead Reduction Ratio		
GVHA	30-300	240-2000	6	TA110 TA115 TA220 TA230 (Single-phase)	IM (Constant Speed Motor)	25 30 36 50 60 75 90 100	H (General Purpose, Green) W (General Purpose, White) S (For Sliding, Green) G (For Sliding, White) D (For Electronic Parts Transfer, Black) F (For Food Transfer, White) O (Oil Resistant, Navy Blue) N (Non-adhesive, White) J (No Belt)	B (Oriental Motor) C (Taiwanese Motor) *For C, the conveyance speed may decrease by approx. 20%. A (Panasonic Motor) B (Oriental Motor) C (Taiwanese Motor) *SCM (Variable Speed Motor) is not selectable for A. *For C, the conveyance speed may decrease by approx. 20%. R (No Motor, Gearhead)
					SCM (Variable Speed Motor)	120 150 180		
			25	TA110 TA115 TA220 TA230 (Single-phase)	IM (Constant Speed Motor)	5 7.5 9 12.5 15 18 25 30 36 50		
					SCM (Variable Speed Motor)	60 75 90 100 120 150 180		
			6 25	NV (No Motor)	IM (Constant Speed Motor)	NH (No Gearhead)		

- Connect the motor so that the belt rotates in the direction of conveyance.
- When "No motor, gearhead" is selected, the motor mounting hole pitch will vary depending on the motor output. For the dimension details, see Technical Information in our Conveyor Selection web site.
- When "No motor, gearhead" is selected, this unit will be delivered unassembled. The customer is to assemble the unit by following instructions on the included assembly procedure manual. See our Conveyor Selection site for packaging details.
- Mounting brackets for speed controllers are not included with the variable speed motor. When mounting brackets for speed controllers are required, select [SCB] as an alteration.
- Oil-resistant belts cannot be used in environments where oil adheres to the back face.
- Regardless of belt specifications, it is not recommended to use the belt while the conveyor is tilted.

Part Number	B	Available Sizes																		
		L240-300	L305-400	L405-500	L505-600	L605-700	L705-800	L805-900	L905-1000	L1005-1100	L1105-1200	L1205-1300	L1305-1400	L1405-1500	L1505-1600	L1605-1700	L1705-1800	L1805-1900	L1905-2000	
GVHA	30-50	○	○	○	○	○	○	○	○	○	○	○	○	○	○	○	○	○	○	○
	60-100	-	-	-	-	-	-	-	-	-	-	-	-	-	-	-	-	-	-	-
	110-150	-	-	-	-	-	-	-	-	-	-	-	-	-	-	-	-	-	-	-
	160-200	-	-	-	-	-	-	-	-	-	-	-	-	-	-	-	-	-	-	-
	210-250	-	-	-	-	-	-	-	-	-	-	-	-	-	-	-	-	-	-	-
260-300	-	-	-	-	-	-	-	-	-	-	-	-	-	-	-	-	-	-	-	-

Ordering Example

Part Number - B - L - Motor - Belt Specifications - Motor Manufacturer Selection - Alterations

GVHA - 110 - 805 - 25 - TA220 - IM - 36 - H - A (- MK · FYA · FYB · SCB · NA · WA)

Days to Ship [Configure Online](#)

Alterations: Motor Position Reversed, Additional Counterbores, Brackets for Speed Controller Included, Stands (Legs)

Conveyor weight

*Reference values (vary depending on motor manufacturer) (kg)

Belt Width B (mm)	Distance between Pulleys L (mm)			
	500	1000	1500	2000
100	3.9	5.4	6.9	8.5
200	5.0	7.0	9.0	11.0
300	6.1	8.6	11.1	13.6

*When the motor output is 25 W, add 1.5 kg.