

Stage Maintenance Parts

Micrometer Head

Other Information about Stages
 Stage Selection Table P.1639, P.1640
 New Products P.1641
 About Standard Stages P.1642
 Overview, Technical Information P.1643, P.1644

Feature: Micrometer head which enables fine adjustment can be ordered separately.

Micrometer Head



(Dedicated Wrench)

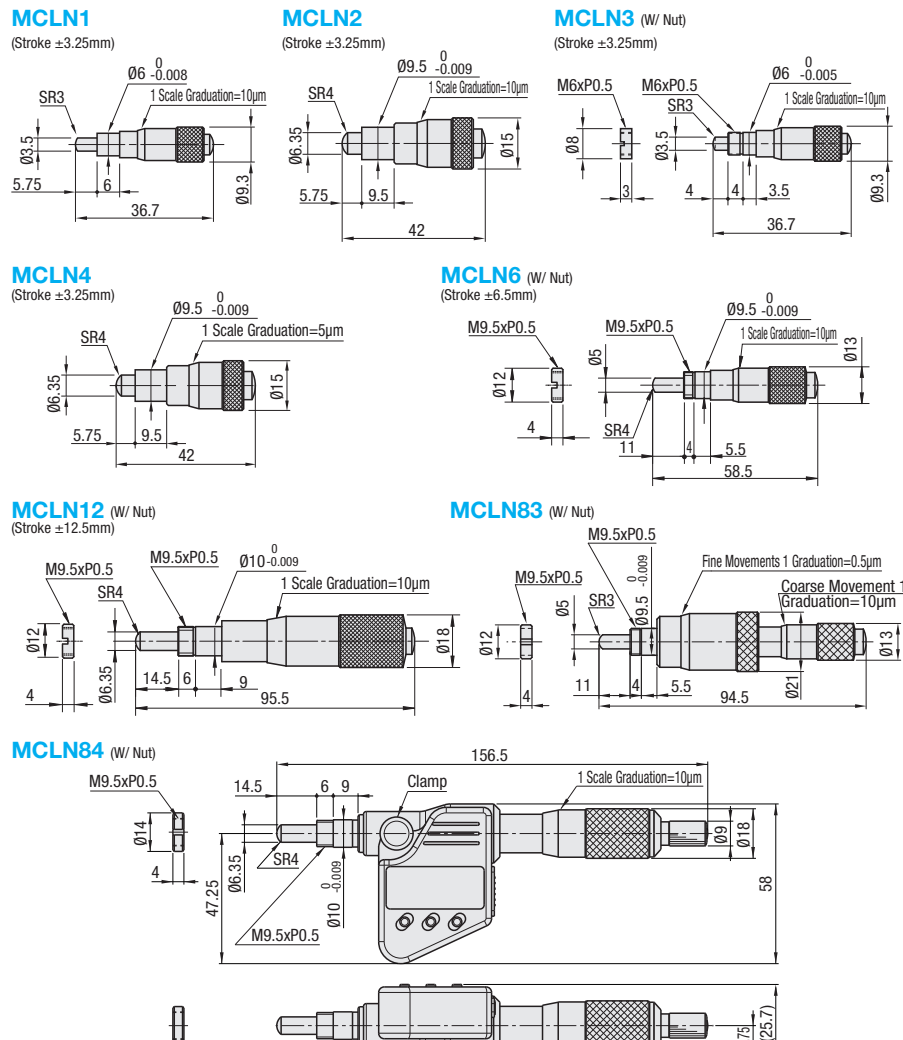

The drawing shows the micrometer in stroke center state.
 Micrometer has a bolt/nut system, so the total length doesn't change.

Material: Spindle: SKS, Handle: SUM, Nut / Thread: Low Cadmium Brass

Accessories: Dedicated Wrench (W Nut Type only)

Standard Micrometer Head (MISUMI Original) RoHS 10



MCMH6

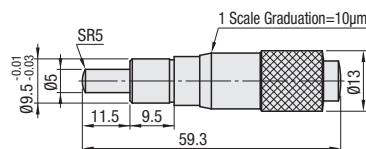

Type	Spindle	Main Body
	Material	Material Surface Treatment
MCMH	416 Stainless Steel	SUM43 Trivalent Chromate

Part Number Type	No.	Stroke (mm)	Minimum Graduation (mm)	Travel Distance per Rotation (mm)	Weight (kg)	Unit Price 1-9 pc(s).
MCLN	1	±3.25	0.01	0.5	0.01	
	2					
	3					
	4	0.005	0.25	0.03		
	6	±6.5	0.01	0.5	0.09	
12	±12.5					
MCMH	83	Coarse Feed ±6.5 Fine Feed 0.2	Coarse Feed 0.01 Fine Feed 0.0005	0.5	0.10	
	84	0~25	0.001	0.5	0.235	
	6	±6.5	0.01	0.5	0.03	



Part Number
MCLN6
MCMH6



Configure Online



Configure Online

For orders larger than indicated quantity, please request a quotation.

Stage Maintenance Parts

Feed Screws / Clamp Screws with Levers / Vernier Scales

Other Information about Stages
 Stage Selection Table P.1639, P.1640
 New Products P.1641
 About Standard Stages P.1642
 Overview, Technical Information P.1643, P.1644

Feature: Precision finished screw/bushing fits minimizes play.

Feed Screw RoHS 10



Knob Type

XBMF (Lead 0.25) (No. =3, 6)
 XBM (Lead 0.5) (No. =3, 6, 12)

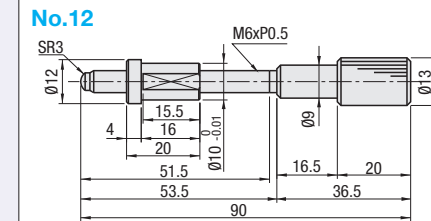
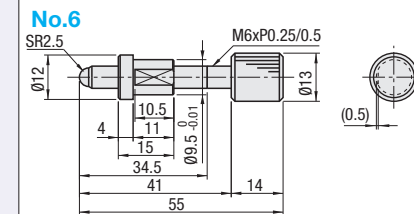
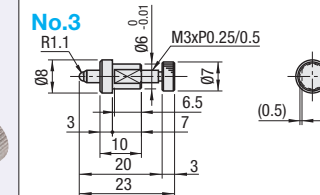

Hex Socket Type

XBRF (Lead 0.25) (No. =3, 6)

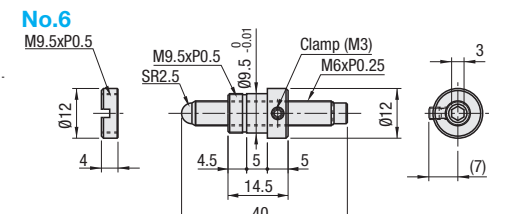
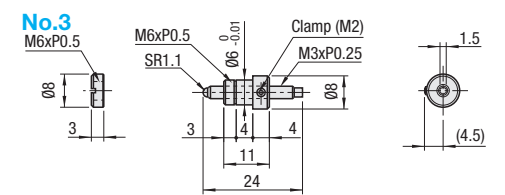

Hex Socket Type can be locked with a set screw on the bushing.

Material: Screw: 303 Stainless Steel, Nut: Low Cadmium Brass

Feed Screw	Part Number (Lead) Type	No.	Stroke	Linear Ball Slide Type / Cross Roller Type	Applicable Stage Surface Size	Weight (g)	Unit Price		Volume Discount Rate	
							1-9 pc(s).	1-2 pc(s).	3-9 pcs.	
With Knob	(0.25) XBMF (* only)	3*	±3.5	25 Square	5					
	(0.5) XBM	6*	±6.5	40-80 square	30					
		12	±12.5	100/120 Square	50					
Hex Socket Head Cap Screw	(0.25) XBRF	3	±3.5	25 Square	5					
		6	±6.5	40-80 square	15					

A dedicated wrench is included with XBRF.



Part Number
XBMF3



Configure Online



Configure Online

Feature: Clamp Screws with Levers: More torque can be applied for clamping compared to the standard clamp screws. Dovetail slide stage clamps can be reinforced.

Clamp Screws with Levers for Dovetail Stages RoHS 10



STRONG3

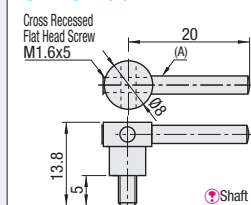

STRONG3W (With Washer)

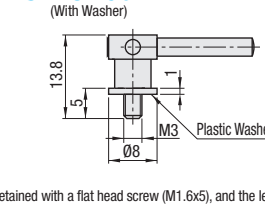

Shaft (A) is retained with a flat head screw (M1.6x5), and the lever position can be turned by 90 degrees by removing the screw and rotating the shaft.

Type	No.	Applicable Stage
STRONG	3	XLWG(P1669), XSL(P1673), XSO(P1672), XSSLP(P1674)
	3W	XWGP(P1663), XSL(P1673), XSSLP(P1674), XSP(P1668), XSB(P1665)
	4	XLONG(P1700)

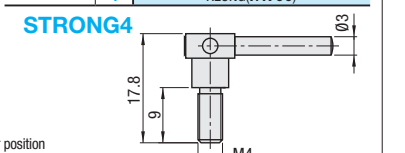

Material: Lever: Stainless Steel, Screw: Low Cadmium Brass

Vernier Scales RoHS 10

Scale Board (Main Scale)

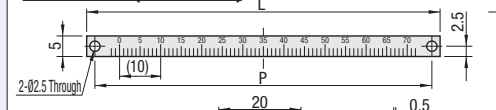

Scale Board (Vernier Scale)

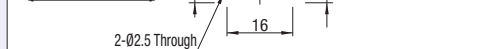

Type	No.	L	P	Applicable Stage
VNIR	40	36	32	XWG, XWVG, XSL, XSLC, XSC, XSSL, XSSLC
	60	56	52	
	90	86	82	
	140	136	132	

Resolution: 0.1mm
 See the XY Stage Overview pages for vernier scale reading instructions. P.1644

Material: 1050 Aluminum Alloy

Part Number Type	No.	Unit Price 1-4 pc(s).	Volume Discount Rate 5-7 pcs.	8-9 pcs.	Unit Price	
					1-9 pc(s).	
STRONG	3					
	3W					
	4					
VNIR	40					
	60					
	90					
	140					

For orders larger than indicated quantity, please request a quotation.

For orders larger than indicated quantity, please request a quotation.