



LIMIT GAUGES

— STANDARD GRADE, ONE END TYPE · STANDARD GRADE, BOTH ENDS TYPE —

PRECISION CARBIDE PIN GAUGES

Ⓜ A quality assurance certificate is provided with these products.



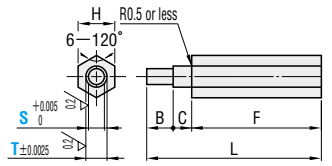

SGSA3~13



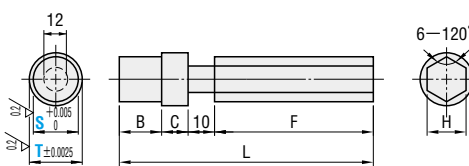

① Handle part
 M SS400
 S Black oxide (Fe₃O₄)

SGSA16~20



② Gauge part
 M SKS3
 H 58HRC ~



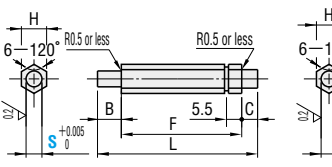

SGWA3~13



① Handle part
 M SS400
 S Black oxide (Fe₃O₄)

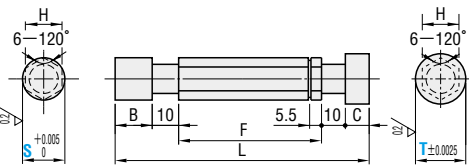

SGWA16~20



② Gauge part
 M SKS3
 H 58HRC ~

Ⓜ S+0.007<T

Ⓜ A quality assurance certificate is provided with these products.



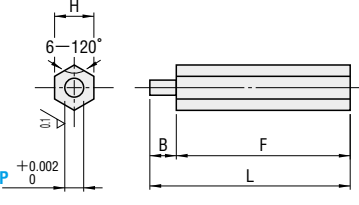

VGOA1.6~6



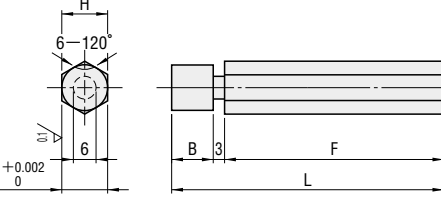

① Handle part
 M Aluminum
 S Black alumite

VGOA8~10



② Gauge part
 M V20
 H 88 ~ 89HRA

VGOB

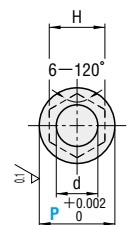

① Handle part
 M Aluminum
 S Black alumite

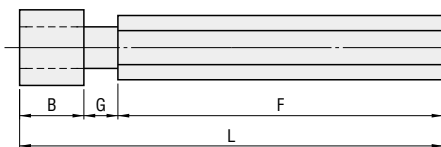

② Gauge part
 M V20
 H 88 ~ 89HRA

Ⓜ S+0.007<T

L	SGSA	SGWA	B	C	F	H	Catalog No.		S-T		Base unit price 1 ~ 9 pieces	
							Type	No.	0.001mm increments	SGSA	SGWA	
40	40	40	4	6	30	8	SGSA SGWA	3	1.000 ~ 3.000	Quotation		
55	55	55	8	7	40	8		4	2.500 ~ 4.000			
65	65	65						5	3.500 ~ 5.000			
67	67	67	10	50	10	6		4.500 ~ 6.000				
80	80	80	12			8		8	5.500 ~ 8.000			
96	106	106	16			10		10	7.500 ~ 10.000			
								13	9.500 ~ 13.000			
								16	12.500 ~ 16.000			
								20	15.500 ~ 20.000			

Ⓜ S+0.007<T

Order **Catalog No.** — **S** — **T**
 SGSA 13 — S10.450 — T10.500

Alterations **Catalog No.** — **S** — **T** — (MC)
 SGSA 13 — S10.450 — T10.500 — MC — S5011

Alteration		Code	Spec.	1Code
SGSA	SGWA			
S5011	S5011	MC	Addition of engraving on opposite side of tolerance engraving [Order code] MC—S5011 <Marking range> •Max. number of characters : 12 (Max. 8 in case of continuous number string) •Available characters : Alphabet letters and numbers — (hyphen / slash) + (plus) * (asterisk), (period)	Quotation

Days to Ship **Quotation**

Price **Quotation**

L	B	F	H	Catalog No.		P	Base unit price
				Type	No.		
38	3	35	5	VGOA	1.6	0.300 ~ 1.600	Quotation
45	5	40	8		2.0	1.601 ~ 2.000	
46	6				2.5	2.001 ~ 2.500	
50	10				3	2.501 ~ 3.000	
60		4	3.001 ~ 4.000				
63		5	4.001 ~ 5.000				
		6	5.001 ~ 6.000				
		8	6.001 ~ 8.000				
		10	8.001 ~ 10.000				

L	B	G	d	F	H	Catalog No.		P	Base unit price
						Type	No.		
78	12	6	7	60	12	VGOB (Large diameter type)	14	10.000 ~ 14.000	Quotation
94	16	8	9	70	14		18	14.001 ~ 18.000	
98		12	12	17	24		18.001 ~ 24.000		

Order **Catalog No.** — **P**
 VGOA 4 — P3.500
 VGOB 14 — P13.500

Days to Ship **Quotation**

Price **Quotation**

Alterations **Catalog No.** — **P** — (AC·BC·MC)
 VGOA 4 — P3.500 — BC8—MC—S5011
 VGOB 14 — P13.500 — AC — MC — S5011

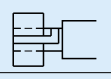
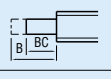
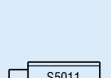
Alteration	Code	Spec.	1Code
	AC	Machining of a φ 2 air hole in the neck of the gauge Ⓜ Can be used for VGOB type only.	Quotation
	BC	1 ≤ BC < B 0.1mm increments Full length L is shortened by (B—BC). Ⓜ Can be used for VGOA type only.	
	MC	Addition of engraving on opposite side of tolerance engraving [Order code] MC—S5011 <Marking range> •Max. number of characters : 12 (Max. 8 in case of continuous number string) •Available characters : Alphabet letters and numbers — (hyphen / slash) + (plus) * (asterisk), (period)	