

PLATES FOR GAS SPRINGS

—VERTICAL SETTING TYPE—

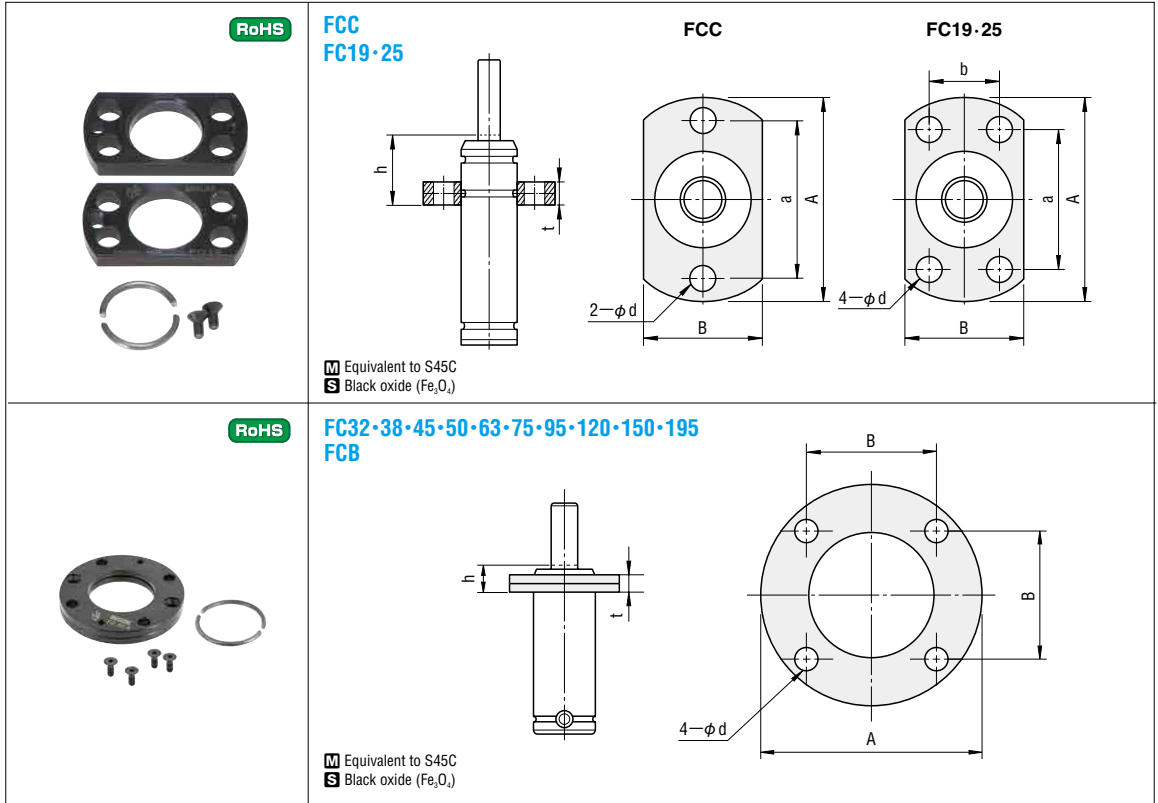

A	a	B	d	t	h			Catalog No.	Adaptable gas spring						Recommended bolts(×2)	
					GSV	GSSC	GSU		GSV	GST	GSH	GSK	GSSC	GSU		
34	24	21	6.6	9	—	—	21.5	FCC	12	—	—	—	—	—	50	CB6 —18
37	27	24	6.6	9	—	—	21.5		15	—	—	—	—	—	70	CB6 —18
44	32	25	6.6	9	21.5	—	21.5		19	170	—	—	—	—	90	CB6 —18
50	38	30	6.6	9	21.5	18	21.5		25	320	—	—	—	400	200	CB6 —18

A	a	B	b	d	t	h				Catalog No.	Adaptable gas spring						Recommended bolts(×4)		
						GSV	GST	GSK	GSU		GSV	GST	GSH	GSK	GSSC	GSU			
44	30	25	12	6.6	9	21.5	—	—	21.5	FC	19	170	—	—	—	—	90	CB6 —18	
50	34	30	18	6.6	9	21.5	—	18	21.5		25	320	—	—	—	400	200	CB6 —18	
60	—	35	—	7	9	17	—	16	15		32	350	350	—	150	750	300	CB6 —18	
68		40		7	9	17	—	15	—		38	500	500	—	250	1000	—	CB6 —18	
86		50		9	13	23	—	—	—		45	750	750	—	500	—	—	CB8 —25	
95		56.5		9	13	24	22	—	—		50	1000	1000	1200	1000	750	—	—	CB8 —25
122		73.5		11	16	27	27	—	—		63	1500	1500	1500	—	—	—	—	CB10—35
122		73.5		11	16	29	29	—	—		75	2400	2400	2400	1500	—	—	—	CB10—35
150	92	13.5	18	33	33	—	—	95	4200		4200	4200	3000	—	—	—	CB12—40		
175	109.5	13.5	21	36	36	33	—	120	6600		6600	6600	5000	12000	—	—	CB12—40		
220	138	17.5	27	41	—	38	—	150	9500		12000	9500	—	—	18500	—	CB16—55		
290	170	17.5	27	—	—	—	—	195	20000		—	—	10000	—	—	—	CB16—55		

A	B	d	t	h	Catalog No.	Adaptable gas spring		Recommended bolts(×4)
						GSSC		
95	56.5	9.0	13	21	FCB	50	1800	CB8 —30
122	73.5	11.0	16	27		63	3000	CB10—35
122	73.5	11.0	16	26		75	4700	CB10—35
150	92.0	13.5	18	30		95	7500	CB12—40