

STRIPPER PRESSURE PINS

STRIPPER PRESSURE PINS AND LIFTING COLLARS

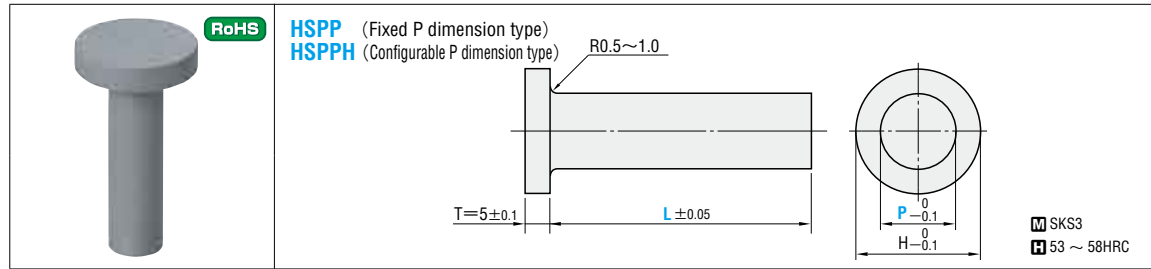

H	Catalog No.		L 0.1mm increments	Base unit price 1~19 pieces	
	Type	P		L10.0~40.0	L40.1~60.0
20	HSPP	8	10.0 ~ 60.0	Quotation	
22		10			
25		13			
27		16			
30		20			
35		25			

H	Catalog No.		L 0.1mm increments	P		Base unit price 1~19 pieces	
	Type	No.		0.5mm increments	L10.0~40.0	L40.1~60.0	
10	HSPPH	10	10.0 ~ 60.0	*5.0 ~ 6.0	Quotation		
16		16		7.0 ~ 12.0			
20		20		7.0 ~ 16.0			
22		22		8.0 ~ 18.0			
25		25		9.0 ~ 21.0			
27		27		9.0 ~ 23.0			
30		30		10.0 ~ 26.0			
35		35		16.0 ~ 30.0			

Order Catalog No. — L — P
 HSPP 10 — 31.5
 HSPPH 25 — 35.8 — P16.5

Days to Ship Quotation

Price Quotation

Alterations Catalog No. — L — P — (HC-TC)
 HSPPH 25 — 35.8 — P16.5 — HC19-TC3

Alteration	Code	Spec.	1Code
	HC	Head diameter change (P+2) ≤ HC < H 0.1mm increments	Quotation
	TC	Head thickness change 2 ≤ TC < 5 0.1mm increments	

- Features**
1. Excellent impact resistance due to the R of 0.5 - 1 under the head
 2. The head diameter is machined to match the coil spring diameter.
 3. Because the shaft diameter dimension (P) can be specified, these products can be used in small spaces. (HSPPH)

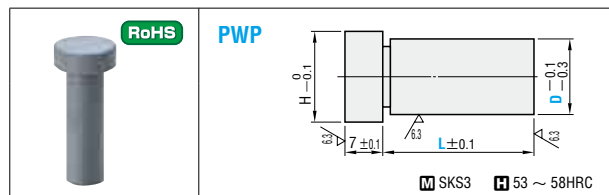
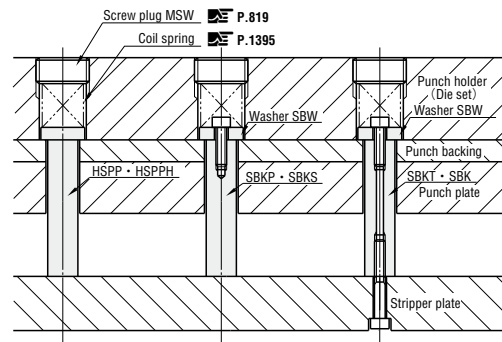

H	Catalog No.		L 0.1mm increments	Base unit price 1~19 pieces
	Type	D		
13	PWP	8	15.0 ~ 70.0	Quotation
16		10		
21		13		
25		16		
30		20		

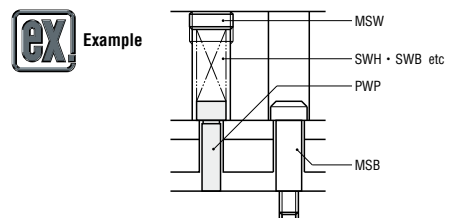

Order Catalog No. — L
 PWP 16 — 50.0

Days to Ship Quotation

Price Quotation

Alterations Catalog No. — L — (HC-TC)
 PWP 8 — 50.5 — HC10-TC3

Alteration	Code	Spec.	1Code
	HC	Head diameter change D ≤ HC < H 0.1mm increments	Quotation
	TC	Head thickness change 2 ≤ TC < 7 0.1mm increments	

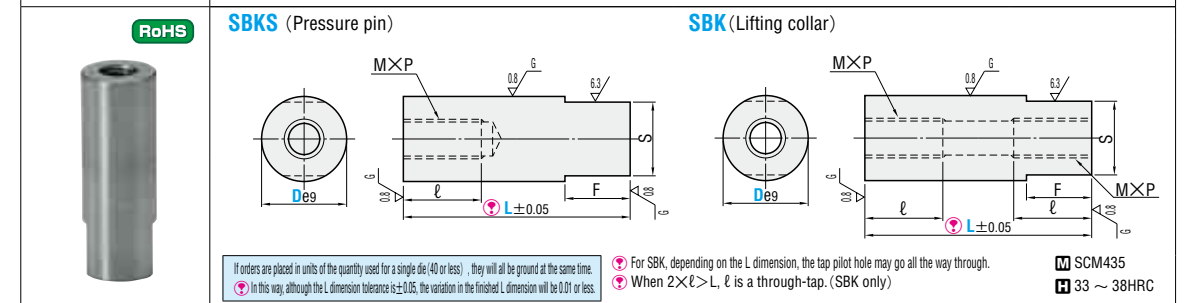
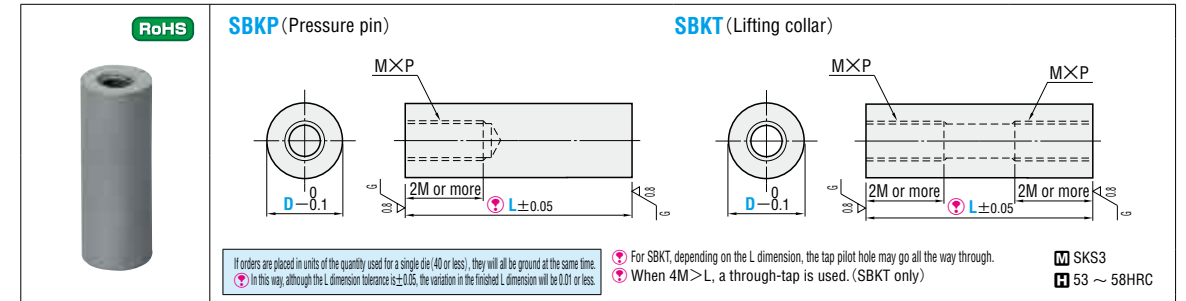

MxP	Catalog No.		L 0.1mm increments	Base unit price 1~19 pieces	
	Type	D		SBKP	SBKT
5x0.8	SBKP SBKT	8	20.0 ~ 60.0	Quotation	
		10			
		13			
		16			
6x1.0	SBKP SBKT	10	20.0 ~ 60.0	Quotation	
11					
12					
8x1.25	SBKP SBKT	14	20.0 ~ 60.0	Quotation	
20					

De9	F	ℓ	S	MxP	Catalog No.		L 0.1mm increments	Base unit price 1~19 pieces	
					Type	D		SBKS	SBK
10	8	15	8	5x0.8	SBKS SBK	10	20.0 ~ 60.0	Quotation	
						13			
13	10	11	11	6x1.0	SBKS SBK	13	20.0 ~ 60.0	Quotation	
						16			
16	12	20	14	8x1.25	SBKS SBK	16	20.0 ~ 60.0	Quotation	

Order Catalog No. — L
 SBKP 16 — 50.0

Days to Ship Quotation

Price Quotation

Alterations Catalog No. — L — (LKC-SC)
 SBKT 13 — 45.0 — LKC

Alteration	Code	Spec.	1Code
	LKC	L dimension tolerance change L±0.05 ⇒ L ^{+0.02} ₀ If LKC is used, L dimension can be selected in 0.01mm increments.	Quotation
	SC	Machining of wrench flat. Can be used for SBKP and SBKT. Cannot be used for SBKT8.	

Washers for pressure pins and lifting collars

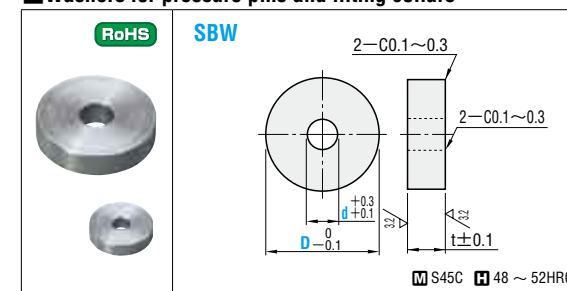

t	Catalog No.		d
	Type	D	
5	SBW	20	5
		22	5
		25	6
		27	5
		30	6
7	SBW	35	8

For delivery and prices P.816