

NEW

EXTEND SOCKET FOR SODICK INJECTION MOLDING MACHINE
EXTEND SOCKET
 DEDICATED FOR SODICK INJECTION MOLDING MACHINE



■ Application Use to remove the plasticizing cylinder of Injection Molding Machine manufactured by Sodick.

RoHS10 M-SES

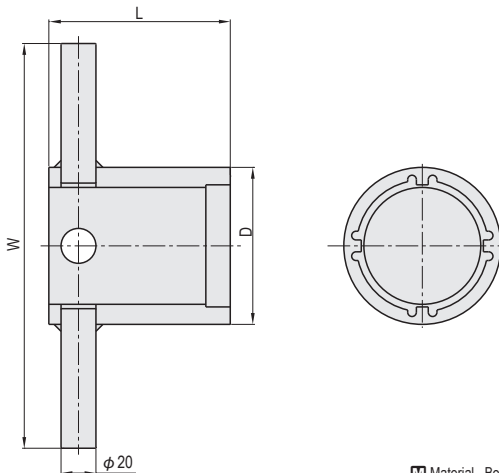

Material Body :S45C
 Handle :SS
 Surface treatment Black oxide

Standardized under the supervision of Sodick Co., Ltd.

No. of handles	W	D	L	Part Number		Unit Price
				Type	No.	1~3 pcs
4	200	73	94	M-SES	14-18	Quotation
	226	80	98		22-25	
	232	90	104		28-32	
6	240	98	105		40	



Order

Part Number
 M-SES-14-18
 M-SES-28-32



Days to Ship

Quotation



Price

Quotation



Example



- Fit the jig to the nut fastened the plasticizing cylinder to loosen it.
- If it cannot be loosened, insert the pipe type jig into the handle and turn the jig.
- ⚠ When performing maintenance on the molding machine, check the Sodick's instruction manual and implement appropriate safety measures against burns and electric shock, etc.
- ⚠ Perform the necessary preparations for removing the plasticizing cylinder, such as removing the plasticizing motor and non-return unit.
- ⚠ In particular, be careful not to let the jig slip off or be damaged when using a pipe type jig.
- ⚠ Pipe type jig P.70