

CARTRIDGE HEATERS

—OUTPUT SELECTION TYPE—

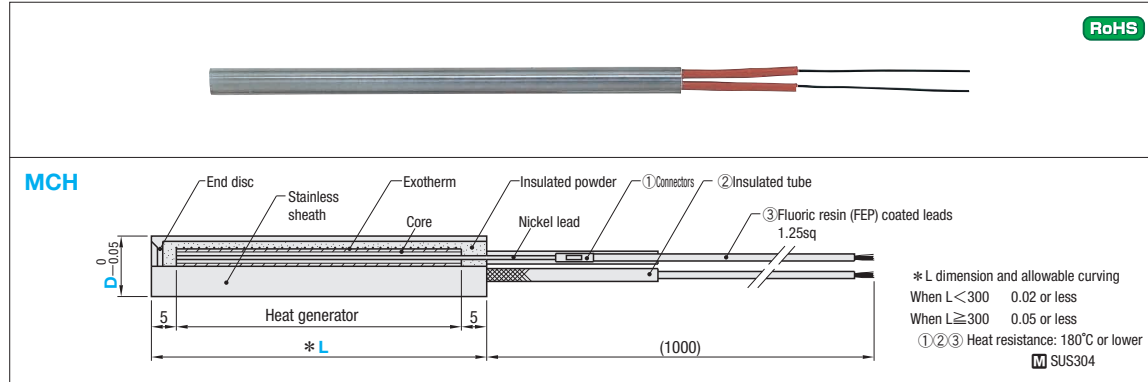

V (Voltage)	W (Wattage)	W/cm ² (Watt density)	Part Number Type	D	L	U/Price 1~9
200	130	5.8	MCH	8	100	Quotation
	200	7.1			100	
	300	8.0			130	
	400	9.1			150	
	400	7.5			180	
	450	7.5			200	
	480	5.3		300		
	400	11.2		100		
	550	11.6		130		
	700	12.6		150		
	800	11.9		180		
	900	11.6		200		
	950	10.5		250		
	1200	10.5		300		
	400	5.7		150		
	550	6.4		180		
650	6.8	200				
750	6.2	250				
1000	6.9	300				



Order Part Number — L
MCH 12.6 — 250



Days to Ship Quotation



Price Quotation



Example right page

Ⓢ Coupling nipples...MCHB (D8~16) right page

CARTRIDGE HEATERS/BOLTS FOR CARTRIDGE HEATER

—OUTPUT DESIGNATION TYPE—

Ⓢ Non JIS material definition is listed on P.1351 - 1352

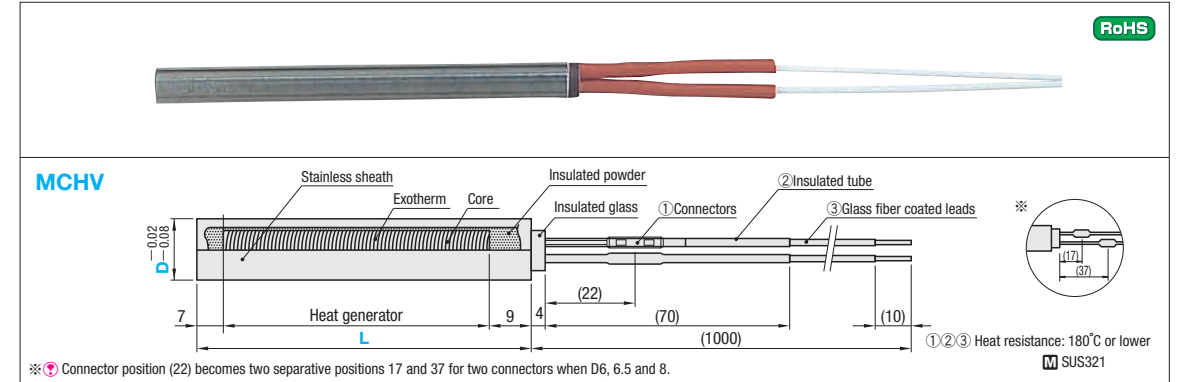

V (Voltage)	W (Wattage)	W/cm ² (Watt density)	Lead nominal cross-sectional area [mm ² ,sq]	Part Number Type	D	L	V	W	U/Price 1~9
100	50	7.6	0.75	MCHV	6	50	100	50	Quotation
	100	6.2				100			
	110	14.5				50			
	250	14.1				100			
	330	14.2				130			
	400	14.3				150			
200	120	14.0	0.75	MCHV	6.5	100	200	250	Quotation
	320	15.2				100			
	350	12.2				130			
	250	7.4				150			
	500	14.8				500			
	300	7.3				300			
200	450	10.9	0.75	MCHV	8	180	200	450	Quotation
	620	15.0				620			
	500	10.8				500			
	690	14.9				200			
	800	17.2				690			
	900	15.3				800			
	900	15.3				250	900		

Ⓢ Coupling nipples...MCHB Ⓢ Coupling nipple SCHL cannot be used.

V (Voltage)	W (Wattage)	W/cm ² (Watt density)	Lead nominal cross-sectional area [mm ² ,sq]	Part Number Type	D	L	V	W	U/Price 1~9	
100	350	13.3	0.75	MCHV	10	100	100	350	Quotation	
	250	12.4				80	250			
	300	11.4				100	300			
	400	15.2				100	400			
	550	13.1				150	550			
	630	15.0				150	630			
	750	17.7				180	750			
	750	14.6				180	750			
	450	7.6				450	450			
	650	11.3				200	650			
	860	14.9				200	860			
	1000	17.2				200	1000			
200	550	7.5	1.25	MCHV	10	200	200	550	Quotation	
	880	12.0				250	880			
	1100	15.0				250	1100			
	1300	17.6				300	1300			
	1100	12.3				300	1100			
	480	15.2				150	480			
	650	12.9				150	650			
	1050	15.1				200	1050			
	1300	14.7				250	1300			
	1500	16.9				2.0	1500			
	890	15.1				1.25	14	150		890

Ⓢ Coupling nipples...MCHB Ⓢ Coupling nipple SCHL cannot be used.

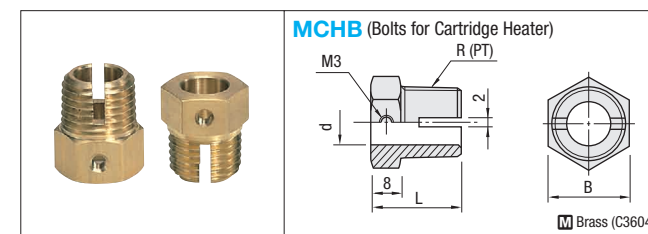

d	B	L	R (PT)	Part Number Type	No.	U/Price 1~9
6.1	14	18	1/8	MCHB	6	Quotation
6.6	17		1/4		6.5	
8.1	21		3/8		8	
10.1	21	20	3/8		10	
12.1	24	25	1/2		12	
12.7					12.6	
14.1				14		
16.1	28	27	3/4	16		



Order Part Number — L — V — W
MCHV10 — 100 — V200 — W400
MCHB8



Price Quotation



Days to Ship Quotation

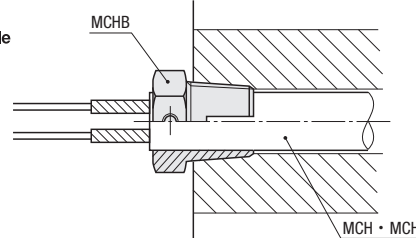

- Having a thread that is shallower than ordinary tapered threads, it enables to fasten a cartridge heater by simply tightening.
- Fix the heater bolt and heater more firmly by M3 bolts from the side surface, if the tightening is weak.
- Ⓢ Do not use with a heater of watt density over 15W/cm².