

Bar Handles

Oval / Square Bar L Dimension Selectable & Configurable / Square Bar U-Shaped Type

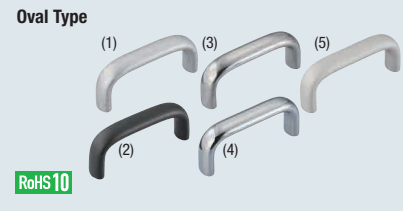

Type	Material	Surface Treatment
(1) UABL	Aluminum Alloy	Tumble Polish
(2) UABR		Electrostatic Coating (Mat Black)
(3) UABLA		Buffed Surface
(4) UABLC	12L13/12L14 Carbon Steel or Equivalent	Chrome Plating
(5) UABS	304 Stainless Steel	Sandblasting

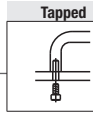
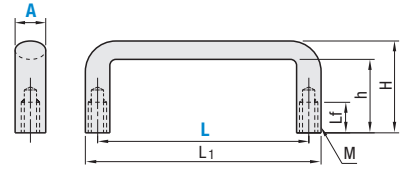

Part Number Type	A	L	L ₁	Lf	H	h	M (Coarse)	Mass (g)	Allowable Load (N)
UABL Tumble Polish	20	100	113	10	47	34	M6	84	1100
		112	125					96	
		120	133					100	
		128	141					106	
		160	173					126	
	26	112	129	12	53	36	M8	157	2300
		120	137					162	
		128	145					178	
		160	177					209	
		192	209					242	
UABR Electrostatic Painted	20	128	145	10	51	38	M6	126	700
		160	177					157	
		192	209					188	
		224	241					219	
		256	273					250	
UABLA Buffed	26	180	197	12	57	40	M8	218	500
		192	209					229	
		204	221					240	
		216	233					251	
		228	245					262	
UABLC Steel	20	128	145	10	51	38	M6	126	470
		160	177					157	
		192	209					188	
		224	241					219	
		256	273					250	
UABS Stainless Steel	26	180	197	12	57	40	M8	218	380
		192	209					229	
		204	221					240	
		216	233					251	
		228	245					262	

Part Number Example: **UABL20 - L100**

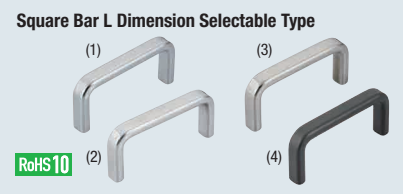

Type	Material	Surface Treatment
(1) USAN	1018 Carbon Steel or Equivalent	Chrome Plating
(2) USANS	304 Stainless Steel	Buffed Surface
(3) USANA	Aluminum Alloy	Buffed Surface
(4) USANB		Electrostatic Coating (Mat Black)

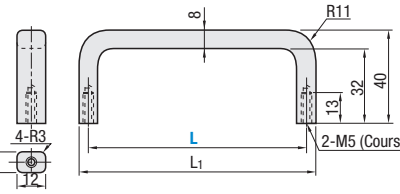

Part Number Type	L	L ₁	Allowable Load (N)	Reference Mass (g)
USAN Steel	80	88	2500	76
	100	108		88
	125	133		103
	160	168		125
	200	208		150
USANS Stainless Steel	125	133	2500	103
USANA Aluminum	160	168	2500	125
USANB Aluminum, Black	200	208	2500	150
	250	258	2500	180

Part Number Example: **USAN80**

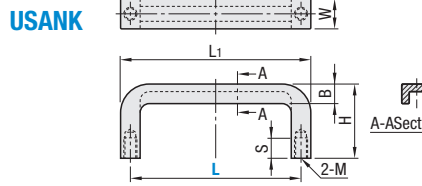
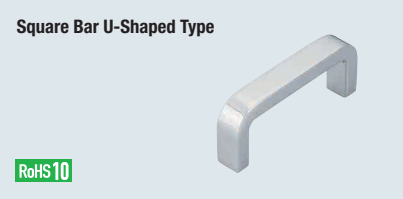

Material	Surface Treatment
Zinc Alloy	Chrome Plating

Part Number Type	L	L ₁	W	H	B	S	M (Coarse)	Reference Mass (g)
USANK U-Shaped	68	76	12	30	8	8	M5	55
	100	108	14	30	8	8	M5	80
	110	120	16	40	10	8	M6	130
	120	130	16	40	10	8	M6	145
	188	200	18	50	12	10	M8	250

Part Number Example: **USANK100**



Type	Material	Surface Treatment
USANSF	304 Stainless Steel	Buffed Surface

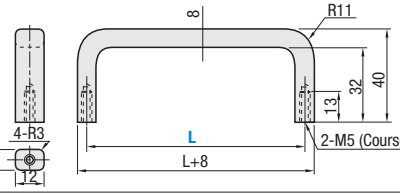

Part Number Type	L 1 mm Increment	Allowable Load (N)
USANSF	80-125	2500
	126-250	
	251-300	

Part Number Example: **USANSF - L85**

Handles

Designer / Phenol Resin

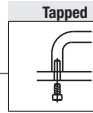

UWSY

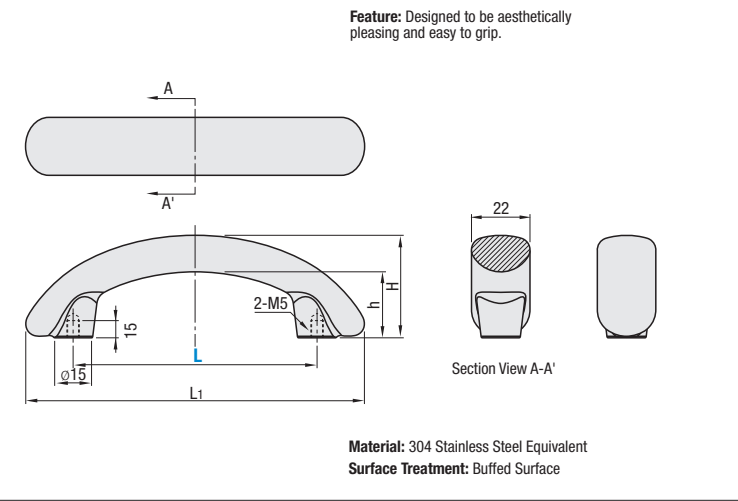

Part Number Type	L	L ₁	H	h	Allowable Load (N)	Mass (g)
UWSY	100	138	42	27	500	351
	150	190	44	29		448



Part Number Example: **UWSY100**



UPCFN

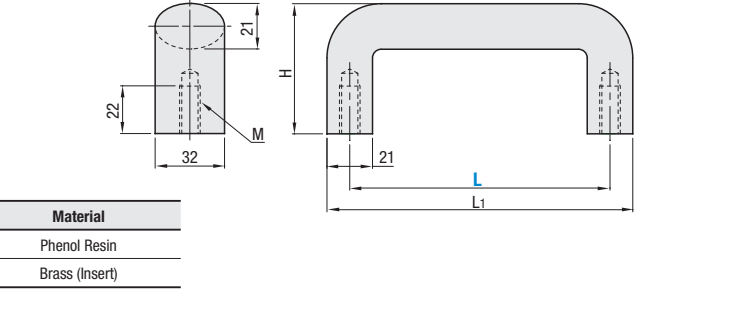

Part Number Type	L	L ₁	M	H	Mass (g)	Allowable Load (N)
UPCFN	90	110	6	50	90	1100
	114	132			105	1100
	120	142			140	700
	140	162	8	60	155	600
	160	182			170	600
	180	202			200	500
	200	222			210	470

Part Number Example: **UPCFN114**