

Leveling Mounts

Compact

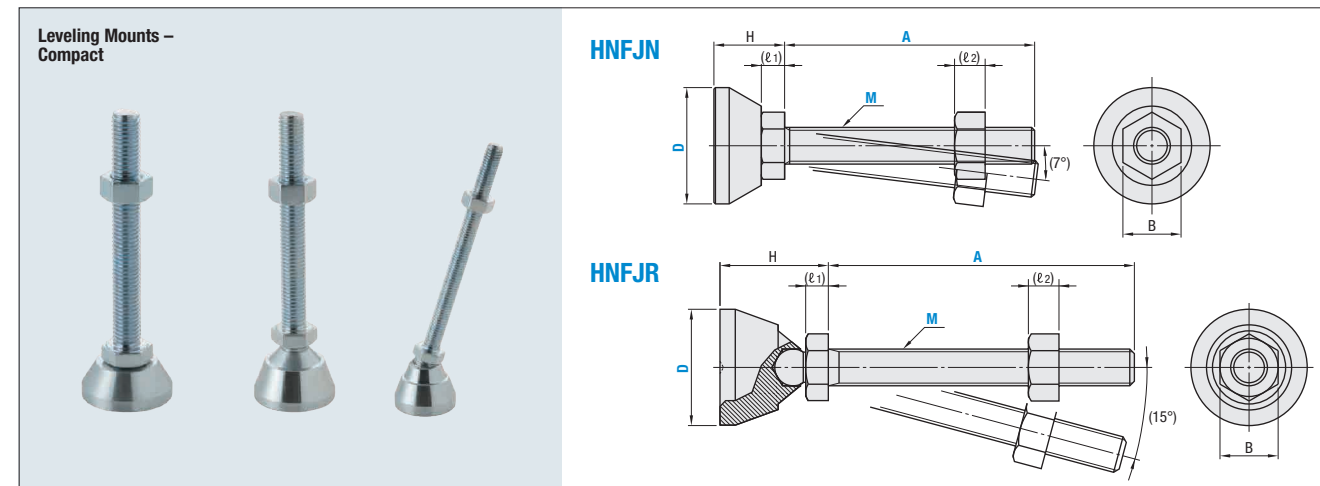

Part Number		M (Coarse)	A			H	ℓ ₁	ℓ ₂	B	Allowable Vertical Load (kN)	Mass (g)		
Type	D		20	30	50							80	100
HNFJN	28	8	20	30	50	80	100	17.7	5.2	6.5	13	6.5	48
		12	20	30	50	80	100	23	7.4	10	19	13	55
	48	8	20	30	50	80	100	20.7	5.2	6.5	13	6.5	77
		12	20	30	50	80	100	23	7.4	10	19	13	90
	58	8	20	30	50	80	100	20.7	5.2	6.5	13	6.5	121
		12	20	30	50	80	100	23	7.4	10	19	13	133

Part Number		M (Coarse)	A			H	ℓ ₁	ℓ ₂	B	Allowable Vertical Load (kN)	Mass (g)		
Type	D		20	30	50							80	100
HNFJR	28	8	20	30	50	80	100	28.2	5.2	6.5	13	6.5	50
		12	20	30	50	80	100	35.4	7.4	10	19	13	59
	48	8	20	30	50	80	100	33.2	5.2	6.5	13	6.5	73
		12	20	30	50	80	100	35.4	7.4	10	19	13	85
	58	8	20	30	50	80	100	33.2	5.2	6.5	13	6.5	115
		12	20	30	50	80	100	35.4	7.4	10	19	13	129

Part Number Example: HNFJR48 - 12 - 80

Leveling Mounts

Swivel / Short Swivel / Tapped Socket

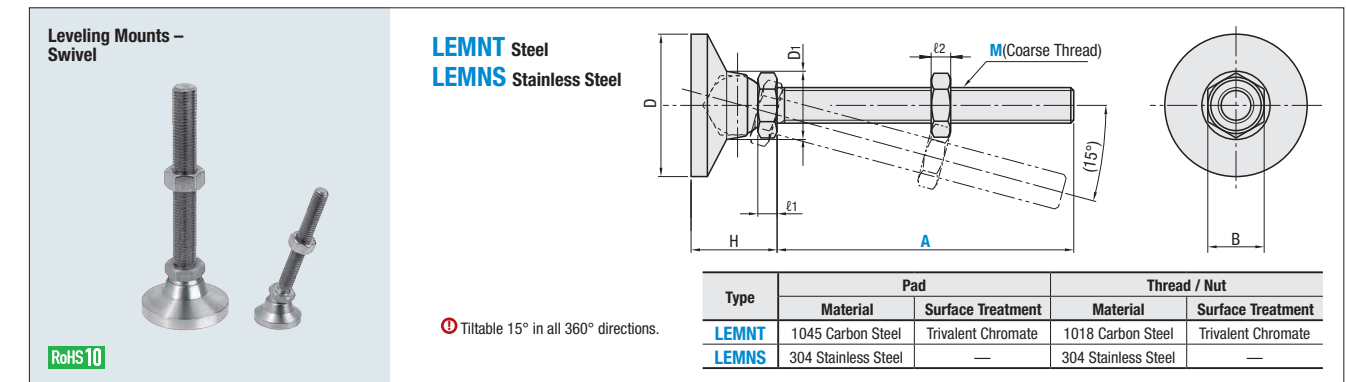

Part Number		D	D ₁	H	ℓ ₁	ℓ ₂	B	Allowable Vertical Load (kN)	Mass (g)
Type	M-A								
LEMNT Steel	10-75	32	21	22	6	8	17	11.0	342
	10-100								
	12-75								
LEMNS Stainless Steel	12-100	48	23	29	7.5	10	19	16.0	378
	16-100								
	16-130								
		64	27	32	10	13	24	28.3	430
									445

Part Number Example: LEMNT16-130

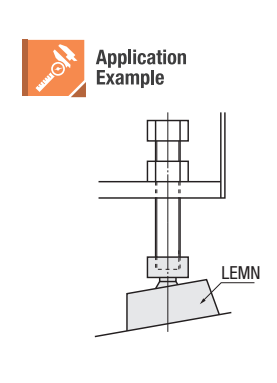
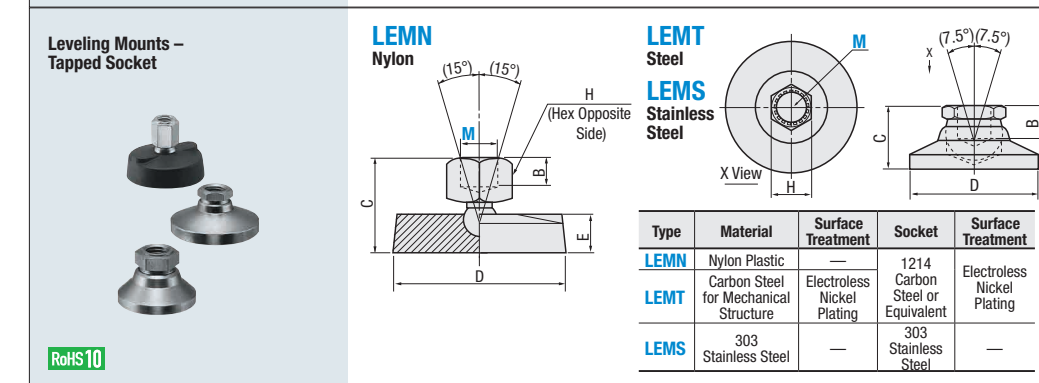
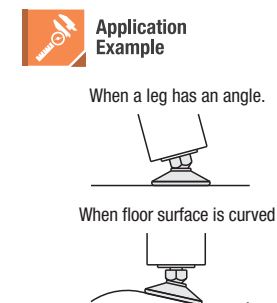
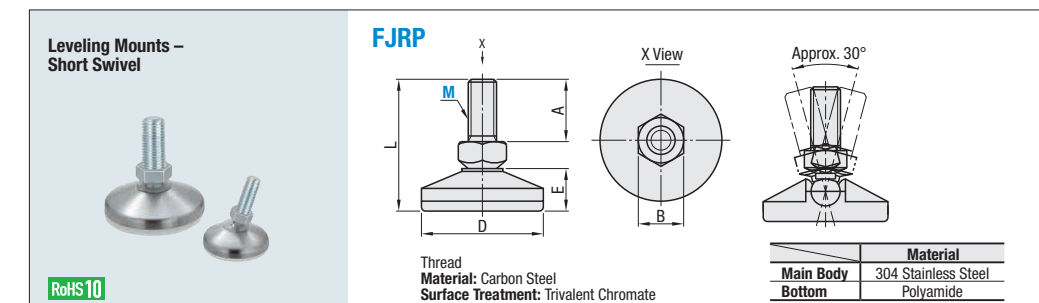

Part Number		A	L	D	B	E	Allowable Vertical Load (kN)	Mass (g)
Type	M (Coarse)							
FJRP	6	14	31	25	8	9.7	0.59	11
	8	19	37.5	30	10	11.2	1.08	21
	10	20	42.5	40	13	13.7	1.57	38
	12	25	51	50	17	16	3.14	70

Part Number Example: LEMN10

Part Number		B	C	D	E	H	Allowable Vertical Load (kN)	Mass (g)
Type	M (Coarse)							
LEMN Nylon	10	9.5	39.0	50	18	16	15.9	17.1
	12							
	16							

Part Number		H	C	D	B	Allowable Vertical Load (kN)	Mass (g)
Type	M (Coarse)						
LEMT Steel	6	10	14	19	4	3.1	17
	8	13	18	25	8	4.1	34
LEMS Stainless Steel	10	17	22	32	10	15.4	65
	12	19	29	48	11	20.5	167
	16	22	32	64	11	24.6	354

Kgf (Load)=Nx0.101972