

Casters

Low Profile

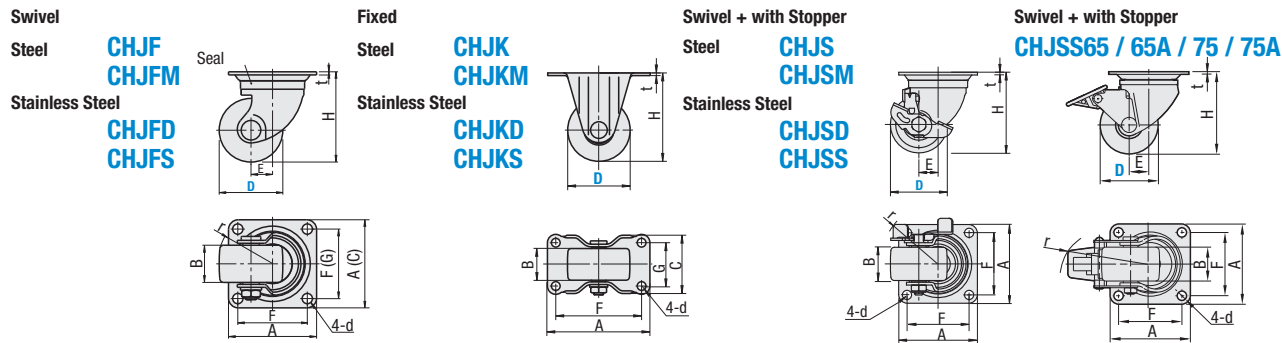

RoHS10



Steel		Type	D	Wheel	Body		Bearing
Swivel	Fixed	Stopper		Material	Material	Surface Treatment	Wheel Bearing
CHJF	CHJK	CHJS	50	Special Reinforced Plastic (Black)	Low Carbon Steel	Trivalent Chromate	Incorporated
			50A				—
			50S				—
			65A				—
			75A				—
65	Phenol (Black)	Incorporated					
75							
CHJFM	CHJKM	CHJSM	50A	MC Nylon (Blue)	Low Carbon Steel	Trivalent Chromate	—
			65				Incorporated
			75				Incorporated
CHJFD	CHJKD	CHJSD	50A	Electrically Conductive MC Nylon (Black)	Low Carbon Steel	Trivalent Chromate	—
			65				Incorporated
			75				Incorporated

Steel

Body Type	Part Number		H	B	A	C	F	G	d	t	E	r	Allowable Load (N)				Mass (g)													
	Type	D											Plastic	Phenol	MC Nylon	Electrical Conductivity MC Nylon														
Swivel	CHJF Plastic / Phenol CHJFM MC Nylon CHJFD Conductive MC Nylon	50	68	28	64	—	50	—	6.5	2.3	25	51	1600	—	—	—	—	340												
		*50A													1600	1600	—													
		*50S													—	—	—													
		65	92	38	90	—	71	—	10.5	3.2	22	57	61	3000	—	3000	3000	3000	870											
		65A														—	—	—												
75	106	—	—	—	—	—	—	—	—	—	—	—	—	3200	3200	3200	970													
75A														—	—	—														
Locked	CHJK Plastic / Phenol CHJKM MC Nylon CHJKD Conductive MC Nylon	50	68	28	80	50	66	36	6.5	2.3	—	—	1600	—	—	—	—	200												
		*50A													1600	1600	—													
		65													92	38	111		70	91	47	10.5	3.2	—	—	—	—	3000	3000	3000
		65A	—	—	—																									
		75	106	—	123	72	103	52	—	—	—	—	—	—	3200	3200	3200	725												
75A	—	—													—															
Swivel + Angle Mount with Brake	CHJS Plastic / Phenol CHJSM MC Nylon CHJSD Conductive MC Nylon	*50A	68	28	64	—	50	—	6.5	2.3	25	65	1600	—	1600	1600	—	380												
		65													92	38	90		—	71	—	10.5	3.2	22	67	—	3000	3000	3000	960
		65A																									—	—	—	
		75	106	—	—	—	—	—	—	—	—	—	—	—	3200	3200	3200	1050												
		75A													—	—	—													

* 50A and 50S have no bearings in wheels.

* 50S type can be served as a replacement caster for aluminum extrusion HAJCHP on P.2920.

Casters

Low Profile, continued



Stainless Steel

Type	D	Body		Wheel	Seal	Bearings	
		Material	Surface Treatment	Material (Color)	Material	Swiveling	Wheel
Swivel CHJFS CHJKS CHJSS	50	304 Stainless Steel	Barrel Grinding	Special Reinforced Plastic (Black)	Urethane	Incorporated	Incorporated
	50A			—			
	65			Phenol (Black)			—
	65A			Special Reinforced Plastic (Black)			—
	75A			Phenol (Black)			—
75	—	—	Incorporated				

ⓘ There is no CHJSS50.

ⓘ All 50A types in this series have no bearing in the wheel.

Stainless Steel

Body Type	Part Number		H	B	A	C	F	G	d	t	E	r	Allowable Load (N)		Mass (g)												
	Type	D											Plastic	Phenol	Plastic	Phenol											
Swivel	CHJFS	50	68	28	64	—	50	—	6.5	2	25	51	1200	—	290	—											
		*50A													—	2300	—	810									
		65													92	38	90	—	71	—	10.5	3	22	57	2300	—	810
		65A	—	2500	—	910																					
		75	106	—	—	—	—	—	—	—	—	—	61	2500	—	910	—										
75A	—	—														—											
Fixed	CHJKS	50	68	28	80	50	66	36	6.5	2	—	—	1200	—	180	—											
		*50A													—	2300	—	580									
		65													92	38	111	70	91	47	10.5	3	—	—	—	—	580
		65A	—	2500	—	620																					
		75	106	—	123	72	103	52	—	—	—	—	—	—	620	—											
75A	—	—													—												
Swivel + Angle Mount with Stopper	CHJSS	50A	68	28	64	—	50	—	6.5	2	25	65	1200	—	330	890											
		65													92	38	90	—	71	—	10.5	3	22	94	—	2300	—
		65A																								—	—
		75	106	—	—	—	—	—	—	—	—	—	—	—	2300	—											
		75A													—	25000	—	990									

*50A types in this series have no bearing in the wheel.

