

Extrusion End Caps

HFS8 Series

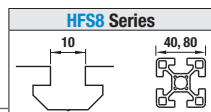

Features: Standard caps for protecting frame end faces. Alterations are not required. When the cap is hard to insert, tap with a wooden or plastic hammer.

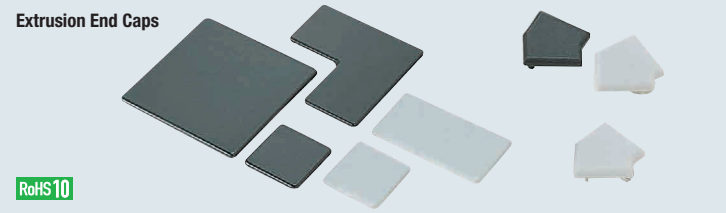

Type	Material
HFC GFC	Polyamide
HFCL	Low Density Polyethylene

- The pin shape and numbers of extrusion caps may be changed to prevent caps from easily falling off.
- Some products are not required to specify colors, since there was no color configuration in the former catalogs. In that case, color is black.

HFC8-4040

HFCL8-4040

HFC8-4080

HFCL8-4080

HFC8-40120

HFC8-8080

HFC8-808040

GFC8-4040

HFC30A8

HFC45A8

HFC60A8

HFCR8-4040

HFC and HFCL can be used for each Aluminum Extrusion other than GFS/GNFS Series.
 For Aluminum Extrusions other than GFS Series, the same extrusion end caps as of HFS Series can be used. For caps for GFS Series, see P.2841.

Type	Part Number	No.	Color	Applicable Extrusion
HFC8		4040	B Black	HFS8-4040
		4080		HFS8-4080
		40120		HFS8-40120
		8080		HFS8-8080
		808040		HFS8-808040
HFCL8		4040	S Light Gray	HFS8-4040
		4080		HFS8-4080
	HFC30A8			HFS30A8-40
	HFC45A8			HFS45A8-40
	HFC60A8			HFS60A8-40
	HFCR8-4040			HFSR8-4040
GFC8		4040	B	GFS8-4040

Part Number Example
 Part Number: HFC30A8 - Color: B

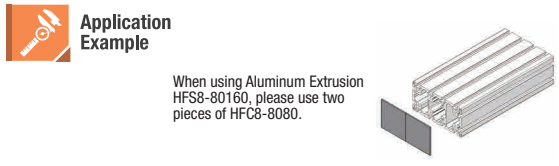

Caps for Corners / Screw Mounted / Plates

For HFS8 Series Aluminum Extrusions 40, 80 mm Square

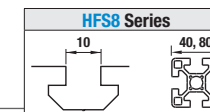

Three-Sided Caps for Corners



HFCK8-4040

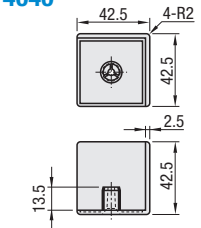

Material: Polyamide
 The pin shape and numbers of extrusion caps may be changed to prevent caps from easily falling off.

Part Number	Color	Accessories	Applicable Extrusion*
HFCK8-4040	B (Black)	HFBMB5-15	HFS8-4040

Part Number Example
 Part Number: HFCK8-4040-B

Application Example

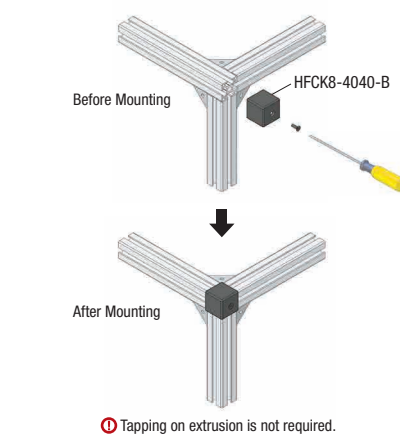

Screw Mounted

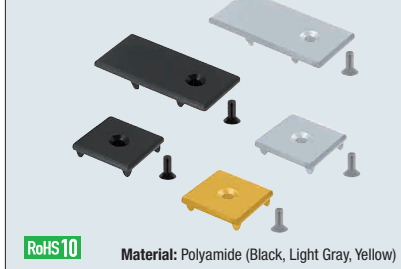

HFCB8-4040 Screw Fixing Type

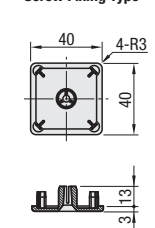

HFCB8-4080 Screw Fixing Type

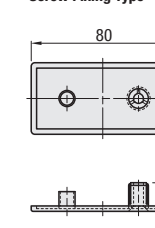

Type	Part Number	No.	Color	Applicable Extrusion*
HFCB8		4040	B (Black) S (Light Gray) Y (Yellow)	HFS8-4040
		4080	Y (Yellow)	HFS8-4080

* For Screw Retained Type, flat head screw is included. (Black: HFBMB5-15, Light Gray, Yellow: SHFBS5-15)

Part Number Example
 Part Number: HFCB8-4040-S

Application Example

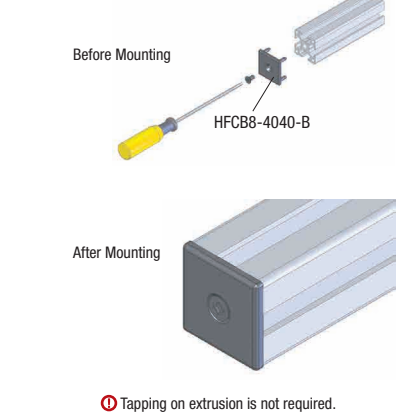

Features: Extrusion End Caps only for High Rigidity Aluminum Extrusions. Alterations are required on the cross sections. P.2864

Plates for High Rigidity Type



HFCD8-4040

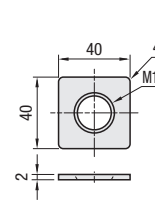

HFCD8-4080

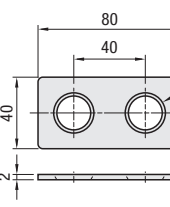

Type	Part Number	No.	Applicable Screw	Applicable Extrusion
HFCD8		4040	SHFBS12-20 (Not included)	GFS8-4040
		4080		GFS8-4080

Part Number Example
 Part Number: HFCD8-4040