

Constant Force Springs

Overview

Constant Force Spring

A long strip of material that is wound into a roll. When the strip is extended the inherent stress resists the loading force, at a constant rate.

Features

- Once it reaches the maximum load, the resistance is constant regardless of the stroke. (The drums reach the max.loads only after a half rotation.)
- Constant Force Springs are extremely compact compared to conventional wire springs because long stroke can be held in small drum.

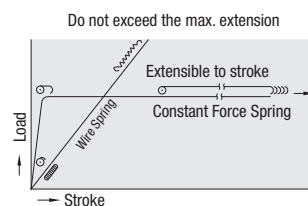

How to Use

- Constant force spring is mounted to a drum, and an accessory plate is attached to the end. The side on which a shaft goes through the drum is regarded as one end, and the accessory plate side as the other end.
- Mount with screws using mounting holes of the accessory plate.
- Can be used in either way of fixing the body and pulling out the accessory plate (Fig.1) or fixing the accessory plate and pulling out the body (Fig.2).
- Use more than one when the output isn't enough.

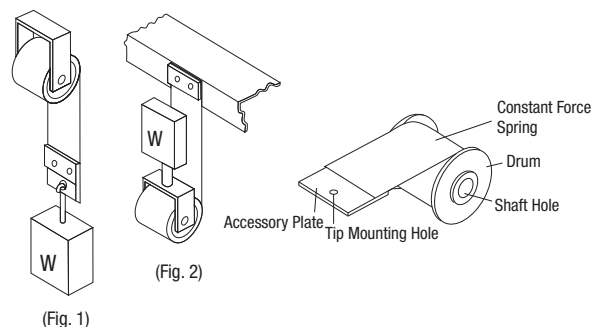

Cautions on Use

- Springs are coiled around a drum without a stopper inside. Do not pull out the stroke beyond the specified length: **the spring may come off of the drum.**
- If a suitable load constant force spring can not be found, select a value one step higher and adjust using a counterweight on the mating load.
- Although the strokes available are only three types, 500 mm, 1000 mm and 1500 mm, they can be used even with extra length if it's within the stroke range.
- Durability is as shown in specification table. A set of extension and contraction is counted as one cycle. If durability expectancy is exceeded, load capacity may decrease and small cracks may appear on the spring surface. **Continuous use under such condition is dangerous.** If used in pairs, both will reach the end of their service life at the same time. Please replace both of them at the same time.

Cautions on Installation

- Make sure the spring doesn't contact other structures.
- Spring draw direction should be perpendicular to the shaft axis.
- Make sure a spring doesn't contact the accessory plate when retracting.
- Set the spring so that it can be pulled out horizontally at any time in order to avoid deflection (bending).
- If drum and shaft do not rotate smoothly, the spring will deteriorate due to excessive force.
- When using brackets, orient in the position as shown in Fig. 3. Orienting in the position as shown in Fig. 4 may cause the spring to contact the brackets and allow foreign objects such as dust inside. This will deteriorate the spring.

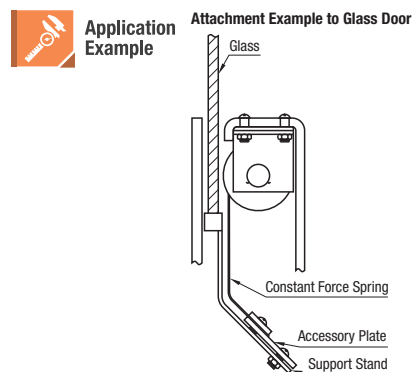
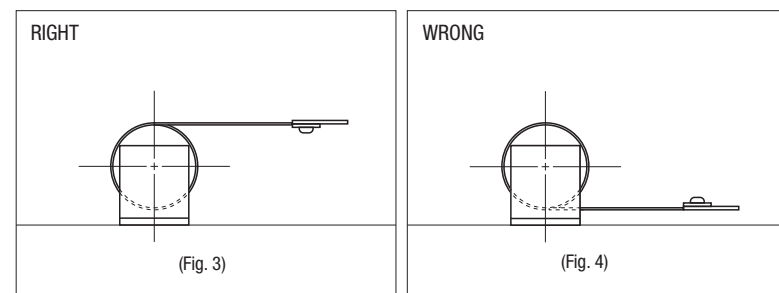

Constant Force Springs / Brackets

Constant Force Springs

RoHS 10

CFS (Constant Force Springs)

Material	
Main Body	Drum
Stainless Steel 301(Equiv)	Polypropylene

Material of the Drums: CFS0.1, CFS0.2 and CFS5.2 are polyethylene, CFS3.5 is ABS Resin.

Part Number	Max. Stroke	Durability Times	Spring Plate Thickness	Accessory Plate Thickness	D	D ₁	V	l	L	W	d	Y				
CFS	0.1	50,000	0.1	1.0	26	8.2	5.2	17	18	10	3.2	5				
	0.2	35,000	0.13													
	0.4	37,000	0.2		34	13							25.6	27.6	20	
	0.6	25,000			34	14							30.6	32.6	25	
	0.8	15,000			38	14							25.6	27.6	20	
	1.0	19,000			44	13							40.6	42.6	35	
	1.2	15,000			34	14							25.6	27.6	20	
	1.4	1,000			9,000	34							13	30.6	32.6	25
	1.8	1,500			9,000	34							14	25.6	27.6	20
	2.0	6,000			0.25	38							14	30.6	32.6	25
	2.2	8,000	0.3	44	14	25.6	27.6	20								
	2.4	6,000	0.25	38	14	30.6	32.6	25								
	2.6	9,000	0.3	44	16	46	49	40	6.5							
	2.9	20,000		2.0	54	16	35.6	37.6	30	4.5						
	3.2	8,000		1.0	44	14	56	58	50	6.5						
	3.5	21,000		2.0	54	16	40.6	42.6	35	4.5						
	3.9	8,000		1.0	44	14	50.6	52.6	45	6.5						
	4.7	9,000		2.0	44	14	37	40	30	4.5						
	5.2	1,500		6,000	0.45	1.0	60	16	37	40	30	4.5				
	5.7	1,000		8,000	0.3	2.0	44	14	55.6	57.6	50	6.5				

All load tolerances are from 0 to +15%. For orders larger than indicated quantity, please request a quotation.

Part Number Example	Part Number
	CFS2.4

Brackets for Constant Force Springs

RoHS 10

CFSB

Material		Surface Treatment		Accessories
Main Body	Shaft	Shaft		
430 Stainless Steel	SWCH Equivalent	Nickel Plating		Retaining Ring-C Type (304 Stainless Steel)

Part Number	No.	t	A	B	P ₁	P ₂	X	d	D	l ₁	l ₂	L	Applicable Constant Force Springs													
CFSB	0.1	1.5	45	22.5	35	12.5	5	4.5	5	24.5	20.5	68.5	CFS0.1	CFS0.2												
	0.4												34.9	30.4	89.4	CFS0.4	CFS0.6	CFS1.4								
	0.8												39.9	35.4	94.4	CFS0.8	CFS1.8									
	1.0												34.9	30.4	94.4	CFS1.0	CFS2.0									
	1.2												49.9	45.4	114.4	CFS1.2	CFS3.9									
	2.2												34.9	30.4	99.4	CFS2.2										
	2.4												39.9	35.4	99.4	CFS2.4										
	2.6												39.9	35.4	104.4	CFS2.6										
	2.9												56.3	51.8	129.4	CFS2.9										
	3.2												44.9	40.4	109.4	CFS3.2										
	3.5												65.3	60.8	139.8	CFS3.5										
	4.7												59.9	55.4	124.4	CFS4.7										
	5.2												47.3	42.3	132.3	CFS5.2										
	5.7												2	65	32.5	53	20.5	6	5.5	10	64.9	60.4	129.4	CFS5.7		

Part Number Example	Part Number
	CFSB2.4