

# Compact Post Clamps

## Equal / Unequal Diameter Perpendicular Configurations

### Compact Post Clamps – Equal Dia. Perpendicular Configuration



RoHS 10

Type	Material	Surface Treatment	Accessories	D	A	F
<b>KDSTR</b>	1018 Carbon Steel or Equivalent	Black Oxide	Hex Socket Head Cap Screws	8	39	11
<b>MDKTR</b>		Electroless Nickel Plating	Hex Socket Head Cap Screws (Stainless Steel Equivalent)	10	43	13
<b>ALKDR</b>	Aluminum Alloy	Black Anodize	Hex Socket Head Cap Screws	15	55	19
<b>SLKDR</b>	304 Stainless Steel	—	Hex Socket Head Cap Screws (Stainless Steel)	20	69	23
				25	83	31
				30	95	35

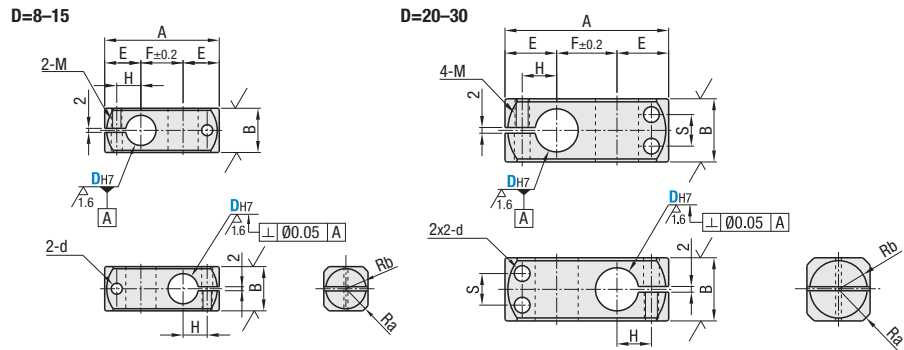

### Compact Strut Clamps – Unequal Dia. Perpendicular Configuration



RoHS 10

Type	Material	Surface Treatment	Accessories	D	A	F
<b>KLSTNR</b>	1018 Carbon Steel or Equivalent	Black Oxide	Hex Socket Head Cap Screws	8	39	12
<b>MLSTNR</b>		Electroless Nickel Plating	Hex Socket Head Cap Screws (Stainless Steel)	10	43	14
<b>ALKLNR</b>	6063 Aluminum Alloy	Black Anodize	Hex Socket Head Cap Screws	15	51	18
<b>SLKLR</b>	304 Stainless Steel	—	Hex Socket Head Cap Screws (Stainless Steel)	20	66	23
				25	74	28
				30	87	32
				35	100	39

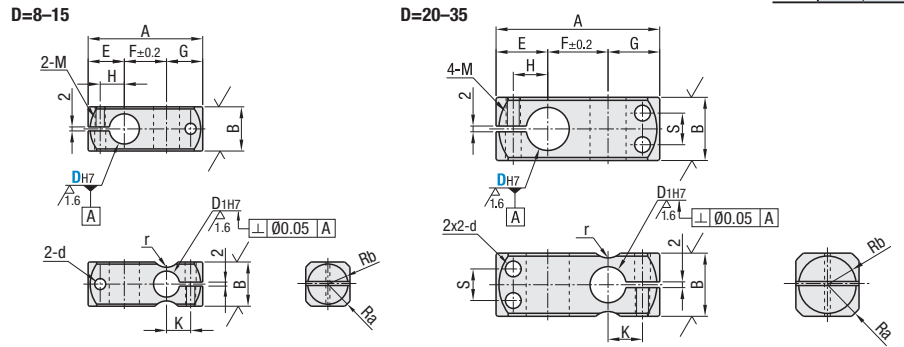

Equal Dia. Perpendicular Configuration	Unequal Dia. Perpendicular Configuration	Part Number		D <sub>H7</sub>	B	E	G	H	K	Ra	Rb	r	S	d	M (Coarse)	
		Type	D <sub>H7</sub>													
KDSTR MDKTR ALKDR SLKDR	KLSTNR MLSTNR ALKLNR SLKLR	8	+0.015	6	+0.012	12	14	13	8	7	7.6	5	3	5.5	M5	
		10	0	8	0	15	14	9	8	9.8	7	4	—			
		12	+0.018	10	+0.015	16	16	10	10	10	10	7	—	6.6	M6	
		15	0	10	0	22	18	15	12	9	13.8	10	5			—
		20	+0.021	15	+0.018	28	23	20	15	12	17.7	13	7.5	11	9	M8
		25	0	15	0	32	26	20	18	12	20.9	15	14	—		
		30	+0.025	20	+0.021	40	30	25	21	16	25.6	19	10	16	9	M8
		35	0	25	0	45	33	28	24	19	29.1	21.5	12.5	18		

- ⓘ ALKLR35, KDSTR35, KLSTNR35, MDKTR35, SLKDR35 has been discontinued.
- ⓘ D dimension 35 is only applicable to MLSTNR and SLKLR.
- ⓘ The tolerance and perpendicularity of D<sub>H7</sub>, D<sub>H7</sub> is the tolerances before slitting.
- ⓘ Recommended tolerances of mating shafts are g6, f8. Use of a long wrench is recommended for fastening.

Part Number Example	Part Number
	<b>KDSTR20</b> <b>KLSTNR20</b>

D	Included Screws	
	Equal Dia., Perpendicular Config.	Unequal Dia., Perpendicular Config.
8	M5-12, 2 pcs.	M5-12, 4 pcs.
10	M5-15, 2 pcs.	M5-15, 4 pcs.
12	M5-15, 2 pcs.	M5-15, 4 pcs.
15	M6-20, 2 pcs.	M6-20, 4 pcs.
20	M6-25, 2 pcs.	M6-25, 4 pcs.
25	M6-30, 2 pcs.	M6-30, 4 pcs.
30	M8-35, 2 pcs.	M8-35, 4 pcs.
35	—	M8-40, 4 pcs.

# Post Clamps

## Equal Diameter Perpendicular Configuration / Reversed

### Post Clamps – Equal Diameter Perpendicular Configuration / Reversed



RoHS 10

### Application Example

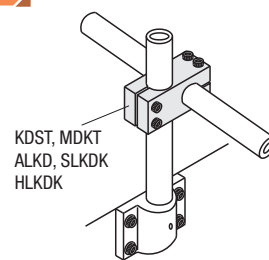

- ⓘ 6063 Aluminum Alloy is applicable to D8-35.
- ⓘ 304 Stainless Steel is applicable to D8-30.

Equal Dia., Perpendicular Configuration	Type	Material	Surface Treatment	Accessories
<b>KDST</b>	<b>KDSTK</b>	1018 Carbon Steel or Equivalent	Black Oxide	Hex Socket Head Cap Screws
<b>MDKT</b>	<b>MDKTK</b>		Electroless Nickel Plating	Hex Socket Head Cap Screws (Stainless Steel Equivalent)
<b>ALKD</b>	<b>ALKDK</b>	Aluminum Alloy	Black Anodize	Hex Socket Head Cap Screws
<b>HLKD</b>	<b>HLKDK</b>		Clear Anodize	Hex Socket Head Cap Screws (Stainless Steel)
<b>SLKD</b>	<b>SLKDK</b>	304 Stainless Steel	—	Hex Socket Head Cap Screws (Stainless Steel)

- ⓘ CB screws are included with the black oxide and black anodized products, and SCB screws are included with the other products

### Equal Dia., Perpendicular Configuration

D=6-12

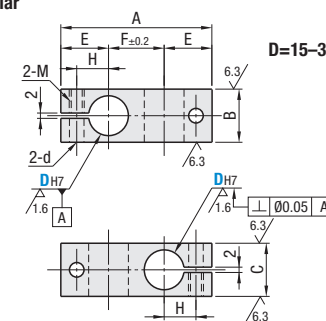

D=15-35

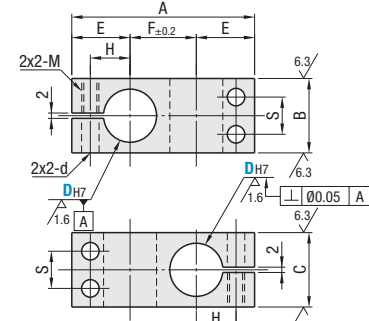

### Equal Dia., Perpendicular Configuration, Reversed

D=6-12

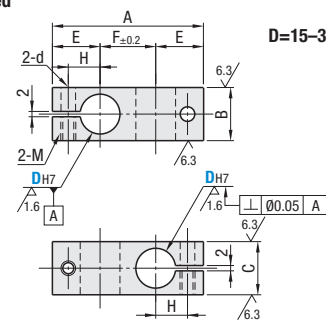

D=15-35

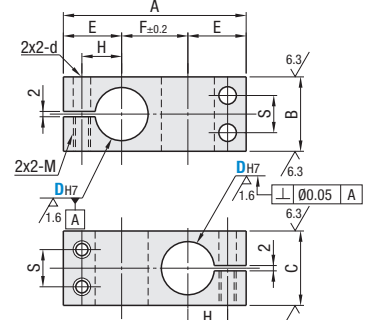

### Fasteners Reversed

- \* The fastening screws are inserted in the opposite direction of the above Same Dia. Perpendicular Configuration.

Equal Dia., Perpendicular Configuration	Type	D <sub>H7</sub>	Part Number		A	B	C	E	F	H	S	M (Coarse)	d	
			Equal Dia., Perpendicular Configuration	Reversed										
KDST MDKT ALKD HLKD SLKD	KDSTK MDKTK ALKDK HLKDK SLKDK	6	+0.012	34	10	10	12	10	7	—	—	M4	4.5	
		8	+0.015	41	12	12	14	13	8	—	—	M5	5.5	
		10	0	45	16	16	15	15	9	—	—			
		12	+0.018	49	16	16	16	17	10	—	—	M6	6.6	
		15	0	57	22	22	18	21	12	11	—			—
		20	+0.021	69	28	28	22	25	15	14	—	—	M8	9
		25	0	83	32	32	25	33	18	16	—	—		
		30	+0.025	95	40	40	29	37	21	20	—	—	M8	9
		35	0	107	45	45	32	43	24	24	—	—		

- ⓘ D Dimension for SLKD and SLKDK is available up to 30.
- ⓘ D Dimension 6 is not available for ALKD, ALKDK, HLKD, HLKDK, SLKD and SLKDK.
- ⓘ The tolerance and perpendicularity of D<sub>H7</sub> is before slitting.
- ⓘ D<sub>H7</sub> Dimension 16 is not available for HLKD and Reversed Type.
- ⓘ For mating, g6, f8 shaft tolerances are recommended. Use of a long wrench is recommended for fastening.

Part Number Example	Part Number
	<b>KDST20</b>

### Included Screws

D	Included Screws
6	M4-10, 2 pcs.
8	M5-12, 2 pcs.
10	M5-15, 2 pcs.
12	M5-15, 2 pcs.
15	M5-20, 4 pcs.
16	M5-20, 4 pcs.
20	M6-25, 4 pcs.
25	M6-30, 4 pcs.
30	M8-35, 4 pcs.
35	M8-40, 4 pcs.