

Simplified Adjustments (XY Axes Push Screw)

Standard Type – Standard Handle

Simplified Adjustment Units

Simplified Adjustments (XY Axes Push Screw) – Standard Type

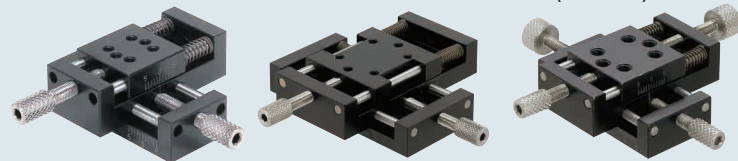

(CL Alteration)

RoHS10

Ⓢ Travel distance per handle rotation: 0.5 mm

How to Mount

- Remove the Push Screw.
- Screw down the A side.
- Move the table manually to the A side.
- Screw down the B side.
- Re-install the Push Screw.

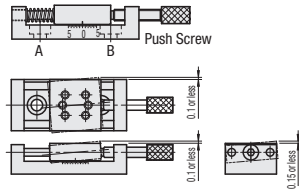

Accuracy Standards

- Ⓢ Not recommended for precise positioning due to its clearance shown on the left. Values are for single-axis configuration.

| Type | Main Body | | Shaft | Spring | Push Screw | | Accessories |
|-------|----------------|-------------------|---------------------|---------------------|------------------------------|----------------------------|--|
| | Material | Surface Treatment | | | Material | Material | |
| XYKNG | Aluminum Alloy | Black Anodize | 303 Stainless Steel | 304 Stainless Steel | 1045 Carbon Steel Equivalent | Electroless Nickel Plating | No. 20, 25 CBS4-6, 2 pcs. No. 40, 60 CBS5-8, 4 pcs. |

XYKNG20

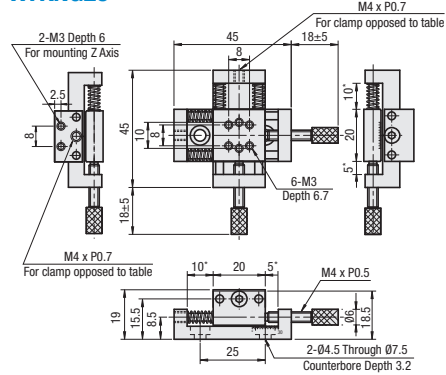

XYKNG25

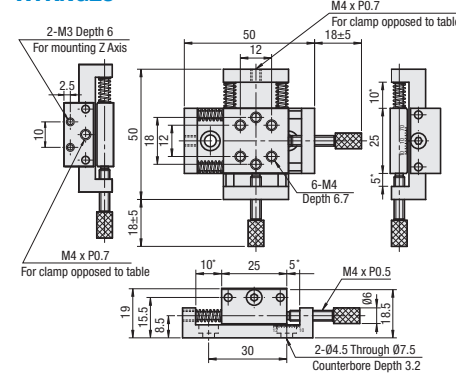

- Ⓢ Not suitable for precise positioning (See Accuracy Standards Chart)
- Ⓢ Minimum Reading 0.5 mm
- *Dimensions are for "Scale aligned at 0 mark".

XYKNG40

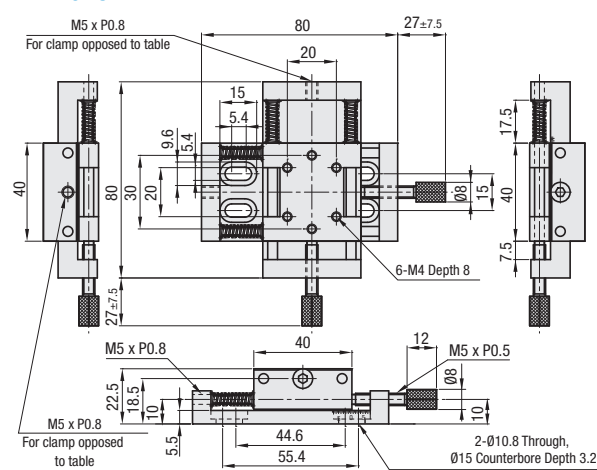

XYKNG60

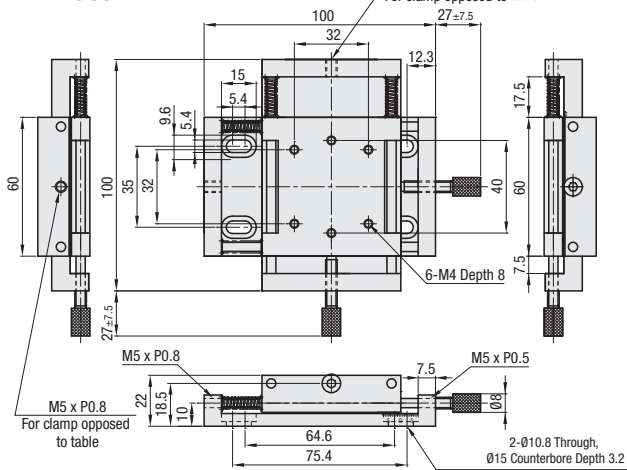

| Part Number | Type | No. | Stage (mm) | Travel Distance (mm) | Load Capacity (N) | Weight (g) |
|-------------|------|-----|------------|----------------------|-------------------|------------|
| | | | | | | |
| | | 25 | 25 x 25 | ±5 | 9.8 | 55 |
| | | 40 | 40 x 40 | ±7.5 | 14.7 | 202 |
| | | 60 | 60 x 60 | ±7.5 | 14.7 | 358 |

Ⓢ Travel per Rotation: 0.5 mm Ⓢ Minimum Graduation: 0.5 mm

Part Number Example: XYKNG20

Part Number Alterations: XYKNG20 - CL

| Alteration | Opposed Clamp Bolt |
|------------|---|
| Code | CL |
| Spec. | <p>Opposing clamp screws are included for immobilizing table (No. 20 / 25: M4 x P0.7, L=30mm; No. 40 / 60: M5 x P0.8, L=44mm). Mounted as shown in the photo.</p> |



ONLINE ORDERING AT YOUR FINGERTIPS

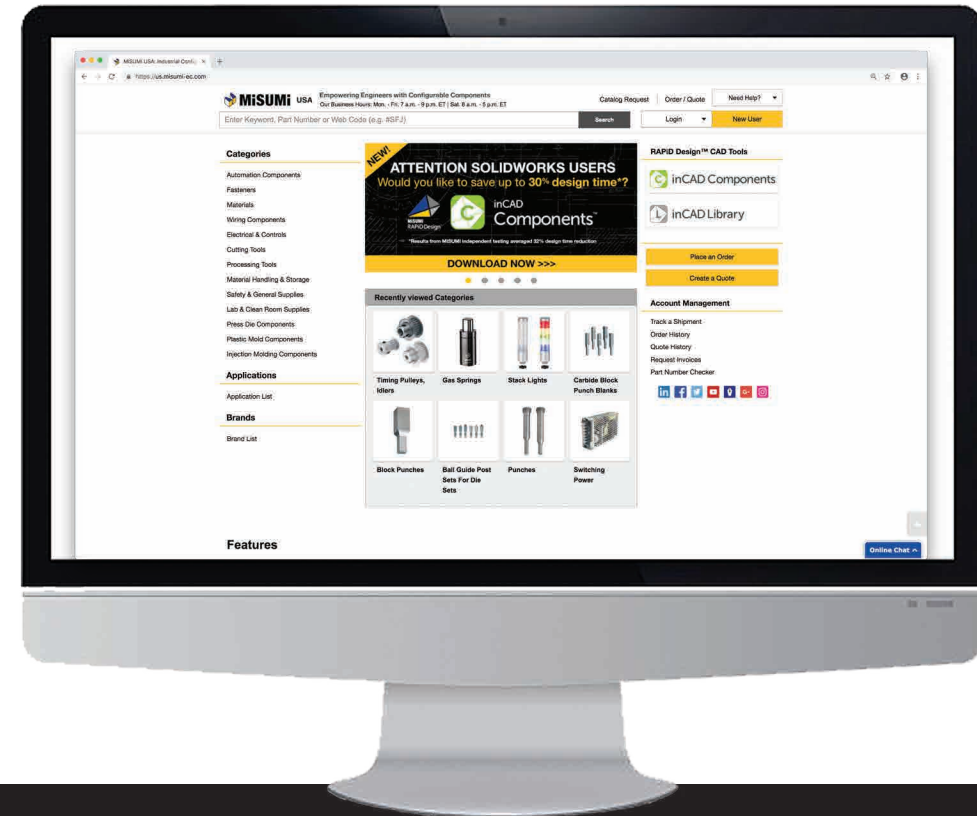

PURCHASING MADE EASY

THE RIGHT PRODUCTS AT THE RIGHT PRICE, WHEN YOU NEED THEM.

ONLINE ORDERING FOR MOST PRODUCTS

NO MINIMUM ORDER QUANTITY

SAME-DAY SHIPPING ON STOCKED COMPONENTS

MISUMIUSA.COM

#80Sextillion