

Sanitary Butterfly Valves / Flange Ball Valves

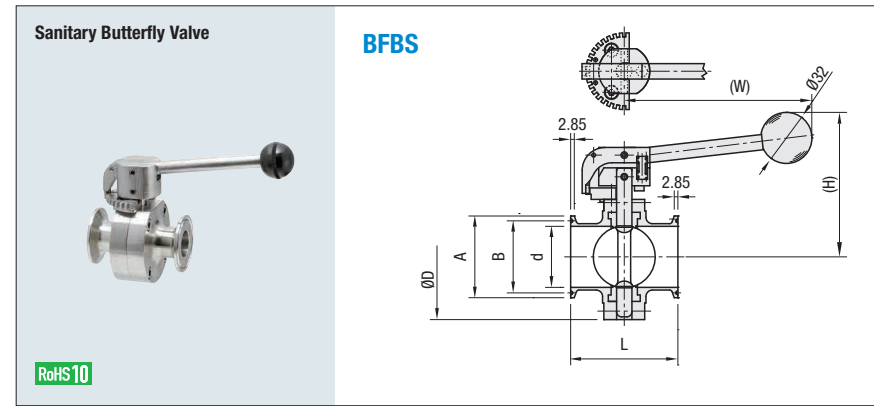

Part Number		d	A	B	D	L	(H)	(W)
Type	No.							
BFBS	1S	23.0	50.5	43.5	74	84	92	142
	1.5S	35.7	50.5	43.5	87	84	99	142
	2S	47.8	64.0	56.5	98	84	105	142
	2.5S	59.5	77.5	70.5	112	100	112	142
	3S	72.3	91.0	83.5	128	100	130	190

Specifications

Applicable Fluid	Water, Air, Oil, Gas	
Max. Operating Temp.	120°C	
Max. Operating Pressure	1S-2S	0.98 MPa
	2.5, 3S	0.78 MPa

Features

- The full-port design minimizes liquid slug.
- The degree of opening can be fixed at a position specifiable in 10° increment.
- The surface pressure being constant maintains air tightness and enables small torque operation.

Parts View

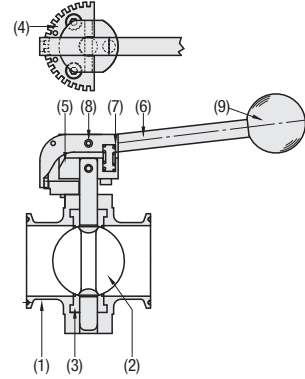

Parts & Materials

Part No.	Name of Parts	Material
(1)	Body	Stainless Steel 316L
(2)	Valve Body	Stainless Steel 316L
(3)	Seat Ring	Silicon Rubber
(4)	Notch Plate	CF-8 SST Casting
(5)	Handle Bracket	CF-8 SST Casting
(6)	Handles	CF-8 SST Casting
(7)	Spring	304 Stainless Steel
(8)	Spring Pins	304 Stainless Steel
(9)	Handle Grip	Plastic

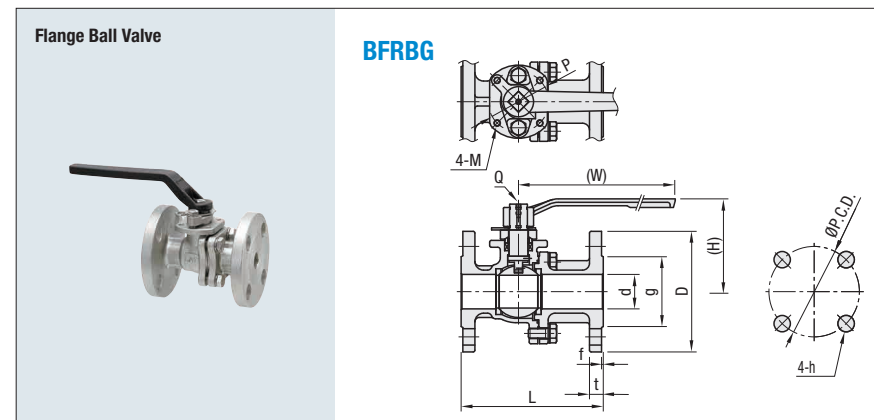

Part Number		d	D	P.C.D.	g	t	f	h	L	(W)	(H)	Q	P	M
Type	No.													
BFRBG	15A	15	95	70	51	12	1	15	108	145	85	M4	42	M5
	20A	20	100	75	56	14	1	15	117	145	92	M4	42	M5
	25A	25	125	90	67	14	1	19	127	165	90	M5	50	M6
	32A	32	135	100	76	16	2	19	140	165	97	M5	50	M6
	40A	38	140	105	81	16	2	19	165	230	108	M5	70	M8
	50A	50	155	120	96	16	2	19	178	230	116	M5	70	M8

Specifications

Applicable Fluid	Water, Air, Oil, Gas	
Max. Operating Pressure	1.4 MPa	

Features

- The full-port design reduces pressure loss.
- Key position can be locked at "Full-Open" and "Full-Close" positions.
- Equipped with anti-static function.

Parts View

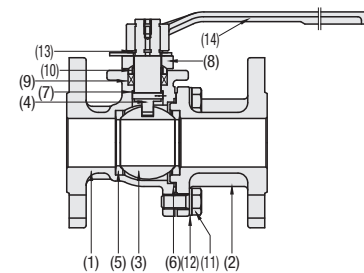

Parts & Materials

Part No.	Name of Parts	Material
(1)	Body	CF-8 SST Casting
(2)	Cap	CF-8 SST Casting
(3)	Ball	CF-8 SST Casting
(4)	Stem	304 Stainless Steel
(5)	Ball Seat	Fluorine Resin
(6)	Gasket	Fluorine Resin
(7)	Thrust Washer	Fluorine Resin
(8)	Gland Nut	CF-8 SST Casting
(9)	Gland Nut Gasket	Fluorine Resin
(10)	Stem Sleeve	Fluorine Resin
(11)	Hexagon Bolt	304 Stainless Steel
(12)	Spring Washer	304 Stainless Steel
(13)	Retaining Ring	304 Stainless Steel
(14)	Handles	60-40-18 Cast Iron



Part Number Example
BFBS1S
BFRBG15A

Sanitary Ball Valves

Standard / Small Diameter

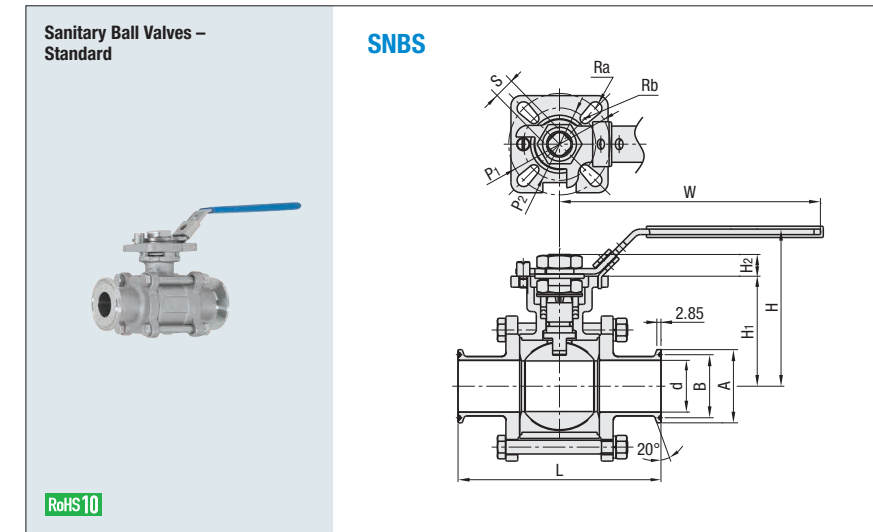

Part Number		d	A	B	L	H	H ₁	H ₂	W	S	P ₁	P ₂	Ra	Rb
Type	No.													
SNBS	1S	23	50.5	43.5	114	87.5	56	11	150	11	50	42	R3.5	R3
	1.5S	35.7	50.5	43.5	140	108.5	76	15	180	14	70	50	R4.5	R3.5
	2S	47.8	64	56.5	156	115.5	83	15	180	14	70	50	R4.5	R3.5

Specifications

Applicable Fluid	Water, Air, Oil, Gas	
Max. Operating Temp.	120°C	
Max. Operating Pressure	0.98 MPa	

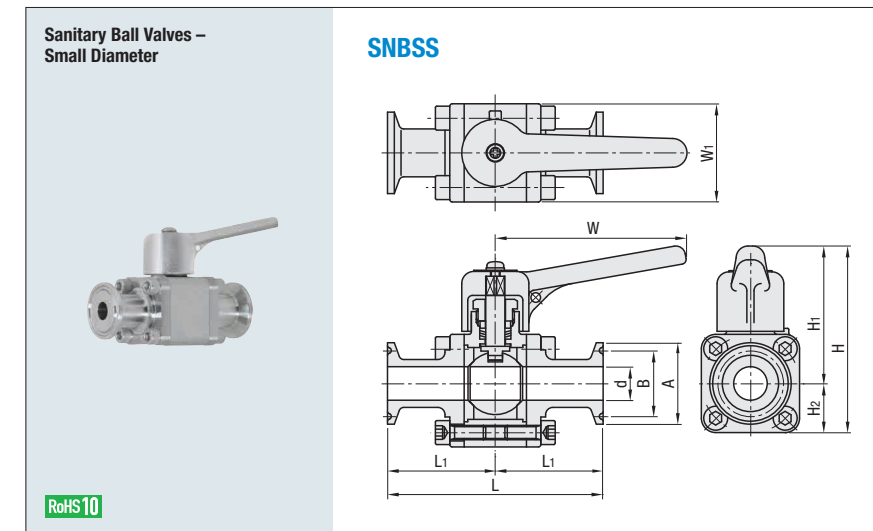

Part Number		d	A	B	L	L ₁	H	H ₁	H ₂	W	W ₁
Type	No.										
SNBSS	8A	10.5	34	27.5	90	45	81	60	21	80	41
	10A	14	34	27.5	90	45	81	60	21	80	41
	15A	17.5	34	27.5	90	45	86	63	23	80	46

Specifications

Applicable Fluid	Water, Air, Oil, Gas	
Max. Operating Temp.	120°C	
Max. Operating Pressure	1S-2S	0.98 MPa
	8A-15A	



Part Number Example
BFBS1S
SNBS1S
SNBSS10A

Parts View

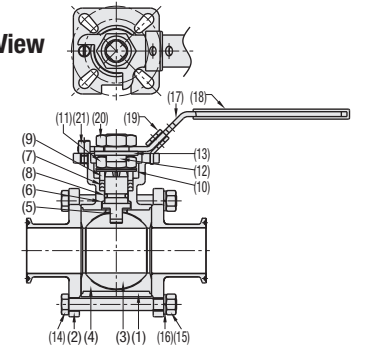

Parts & Materials

Part No.	Name of Parts	Material
(1)	Body	CF-8M Stainless Steel Cast
(2)	End Cap	CF-8M Stainless Steel Cast
(3)	Ball	CF-8M Stainless Steel Cast
(4)	Ball Sheet	Fluororesin
(5)	Stem	316 Stainless Steel
(6)	Thrust Washer	Fluororesin
(7)	Gland Gasket	Fluororesin
(8)	O-Ring	EPDM Synthetic Rubber
(9)	Gland Nut	304 Stainless Steel
(10)	Conical Spring Washer	304 Stainless Steel
(11)	Gland Nut	304 Stainless Steel
(12)	Detent	304 Stainless Steel
(13)	Washer	304 Stainless Steel
(14)	Hex Screw	304 Stainless Steel
(15)	Nut	304 Stainless Steel
(16)	Spring Washer	304 Stainless Steel
(17)	Handle	304 Stainless Steel
(18)	Handle Cover	Plastic
(19)	Locking Plate	304 Stainless Steel
(20)	Stem Nut	304 Stainless Steel
(21)	Stop Pin	304 Stainless Steel

Parts View

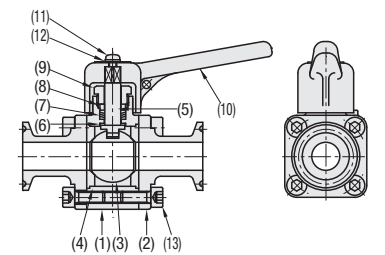

Parts & Materials

Part No.	Name of Parts	Material
(1)	Body	CF-3M SST Casting
(2)	Cap	CF-3M SST Casting
(3)	Ball	CF-3M SST Casting or 316 Stainless Steel
(4)	Ball Seat	Fluorine Resin
(5)	Stem	316 Stainless Steel
(6)	Thrust Washer	Fluorine Resin
(7)	Gland Nut Gasket	Fluorine Resin
(8)	Gland Ring	316 Stainless Steel
(9)	Gland Nut	304 Stainless Steel
(10)	Handles	CF-3M SST Casting
(11)	Cross-Recessed Head Machine Screw	304 Stainless Steel
(12)	Spring Washer	304 Stainless Steel
(13)	Socket Hex Head Bolt	304 Stainless Steel