

MOTORIZED STAGES X-AXIS LINEAR BALL CAVE-X POSITIONER

[High Precision] Motorized X-Axis – Linear Ball, CAVE-X POSITIONER

Compact

Features: Are excellent in rigidity and are compact in width. The overall length is also designed for space-saving.

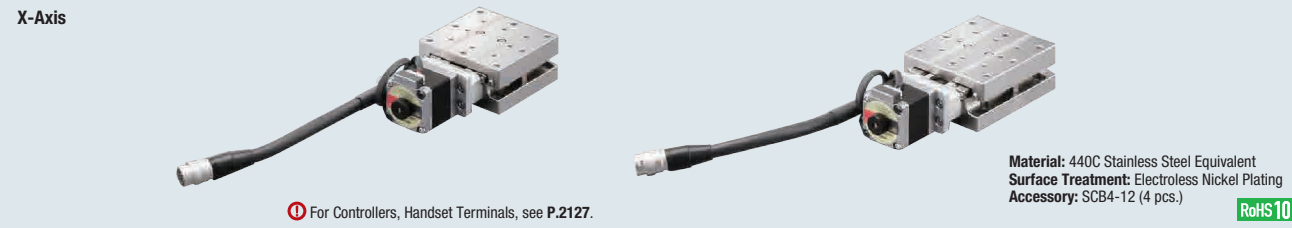

XCV620-C-N

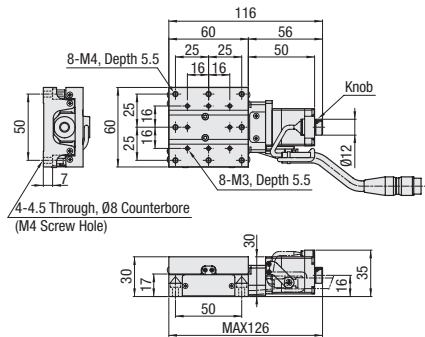

XCV630-C-N

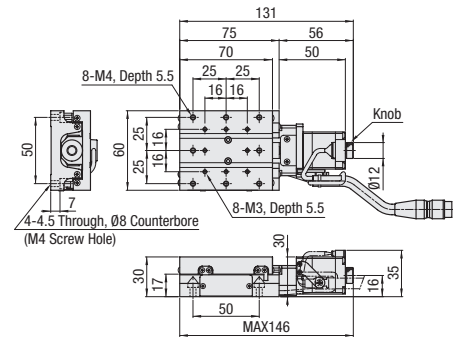

XCV620-F-N

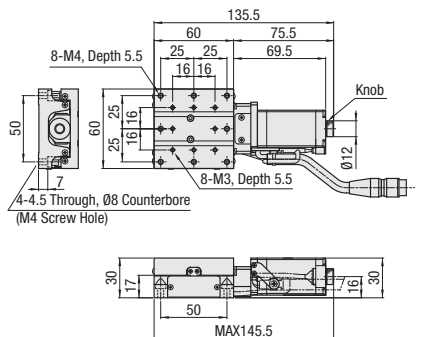

XCV630-F-N

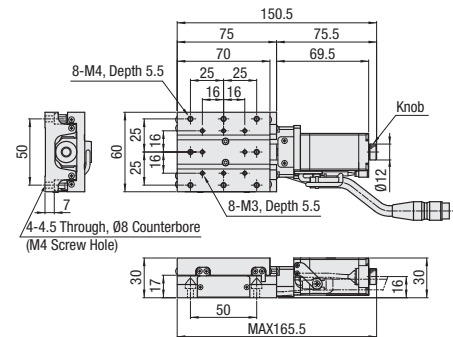

XCV620-G-N

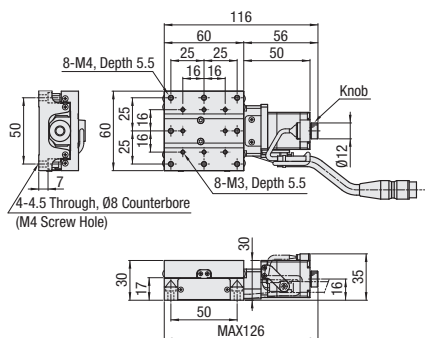

XCV630-G-N

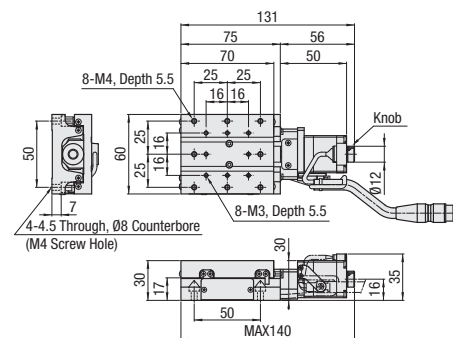

For the detailed dimensions of CAVE-X Positioner with the Motor MA or PA installed, see the applicable CAD data.

MOTORIZED STAGES X-AXIS LINEAR BALL CAVE-X POSITIONER

[High Precision] Motorized X-Axis - Linear Ball, CAVE-X POSITIONER

Compact, continued

Part Number	Motor	Cable	Mechanical Standards			Unidirectional Positioning Accuracy	Accuracy Standards				
			Stage Surface (mm)	Travel Distance (mm)	Weight*3 (kg)		Moment Rigidity (**/N*cm)				
XCV620	C (Standard)	N (Cable not included (separately sold))	60 x 60	20	0.78 (0.87)	5µm	Pitching	Yawing	Rolling	Pitching	Yawing
	F (High Torque)	M (For Motor with Electromagnetic Brake)									
XCV630	G (High Resolution)	P (For α-Step)	60 x 70	30	0.9 (0.99)	5µm	Pitching	Yawing	Rolling	Pitching	Yawing
	MA (With Electromagnetic Brake)	P (For α-Step)									

ⓘ For motor options MA and PA, the driver is included in the set. With motor options MA and PA, the selectable cable options are M and P, respectively and exclusively. Note that the cable option N is not selectable.
 *1 The value differs depending on the type of motor. The above raw values are for stages incorporating Motor C (Standard) and the values in () for stages incorporating Motor F (High Torque).

Part Number Example: XCV620 - C - N

Motor/Cable Application Table

The available cable differs depending on the type of motor.

Motor/Cable Application Table	Motor	Cable
	C, F, G	N (Not Provided)
	MA	M
	PA	P

Max. Speed

Motor	Cable
C	30
F	35
G	25
MA	25
PA	40

ⓘ Note that the speed and positioning time will vary depending on the usage conditions. The values shown here are MISUMI's reference values. Operation at these values is not guaranteed.

Electrical Specifications

Feed Screw	Ball Screw Ø8, Lead 1	
Guide	Linear Ball Guide	
Resolution ²	Full	2µm/Pulse (1µm/Pulse) ³
	Half	1µm/Pulse (0.5µm/Pulse) ³
	Fine (Upon 1/20 partitioned)	0.1µm(0.05µm)
Max. Speed ⁴	20mm/sec(30mm/sec) ⁵ (Pulse Rate: 5kHz)	
Positioning repeatability	±0.5µm	
Load Capacity	49N	
Lost Motion	1µm	
Backlash	1µm	
Straightness	3µm	
Parallelism	15µm	
Motion Parallelism	10µm	

*2 This represents the travel distance of stage per one pulse signal.
 *3 The values in () are for Motor Option G (High Resolution).
 *4 This represents the max. speed that can be driven by the recommended controller switched to Full Step mode, with the max. load applied. (The value differs depending on the current driving controller and the current load.)
 *5 The values in () are for Motor Option F (High Torque).
 The value differs depending on the motor option.

Connector Pin Configuration

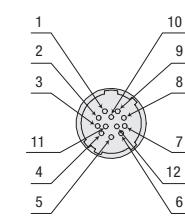

Wiring Diagram

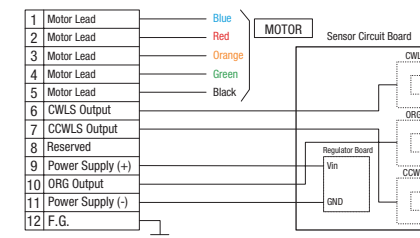

Electrical Specifications

Motor	Type	C	F	G	MA	PA
		Standard	High Torque	High Resolution	With Electromagnetic Brake	Tuningless
	Step Angle	0.72°	0.72°	0.36°	0.72°	0.36° (When set to 1000 P/R)
	Applicable Receptacle Connector	HR10A-10P-12S(73)(Hirose Electric Co., Ltd.)			5559-06R-210 (Molex)	43020-1000 (Molex)
Sensor	Limit Sensor	Provided				
	Home Sensor	Photomicrosensor: EE-SX4320 (OMRON Corp.)				
	Near Home Sensor	-				
	Power Supply Voltage	DC5-24V ±10%				
	Current Consumption	60mA or less in Total				
	Control Output	NPN Open Collector Output DC5-24V, 8mA or less Residual Voltage 0.3V or less (when load current is 2mA)				
	Output Logic	Detecting (Dark): Output Transistor OFF (Non-Conducting)				

Timing Chart

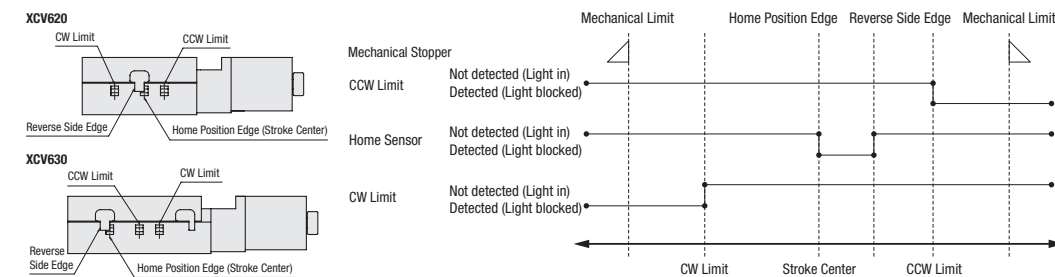

(Unit: mm)	Reference Position	Mechanical Limit	CW Limit	Home Position Edge Stroke Center	Other Signal Edge	CCW Limit	Mechanical Limit
XCV620	Homing	11	10.5	0	5	10.5	13
XCV630	Homing	16	15.5	0	5	15.5	18

• Homing mentioned here means that Homing Routine Type 4 is executed by using the MSCTL102 Series controller.
 • The coordinates shown are design values. There may be approx. ±0.5mm misalignment on the physical dimensions.

Recommended Homing Method

Type	Description
Type 3	After detection is executed in the CCW direction, the process of detecting in the CW direction is begun based on the ORG signal.
Type 4	After detection is executed in the CW direction, the process of detecting in the CCW direction is begun based on the ORG signal.
Type 9	After Type 3 is executed, the process of detecting in the CCW direction is begun based on the TIMING signal.
Type 10	After Type 4 is executed, the process of detecting in the CW direction is begun based on the TIMING signal.