





# Toggle Clamps / Two-Pronged Fittings

Hold Down, Vertical Handle, Two-Pronged (Flange Base) / Long Arm (Flange Base)

 <p>Clamp Condition</p>	Part Number	<b>MC05-1</b>	 <p>Two-Pronged Fittings</p>	Part Number	<b>FTK</b>
	Body Material	1018 Carbon Steel or Equivalent		Body Material	1018 Carbon Steel or Equivalent
	Surface Treatment	Trivalent Chromate		Surface Treatment	Trivalent Chromate
	Tightening Force (N)	800~1500		Weight (g)	550
	Weight (g)	2000		Toggle Clamps Arm Mounting Width	Max. 22 Min. 16
	Right and Left Travel Distance (mm)	40~80		Right and Left Travel Distance (mm)	40~70
	Back and Forth Travel Distance (mm)	60		Back and Forth Travel Distance (mm)	17
	Open-Close Angle of Arm	150°		Accessories	Bolt with Rubber Material: NBR Nitrile Rubber Hardness: Shore A70

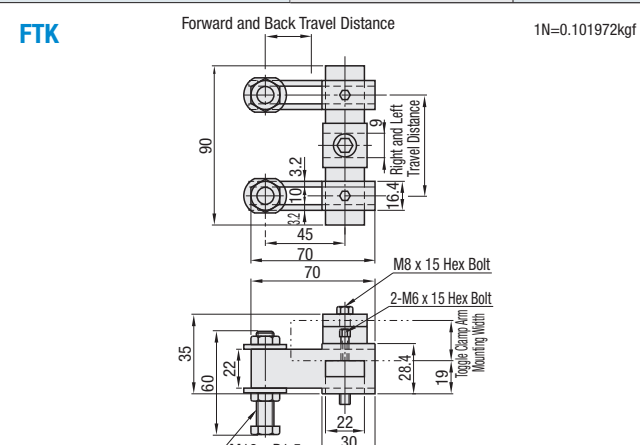
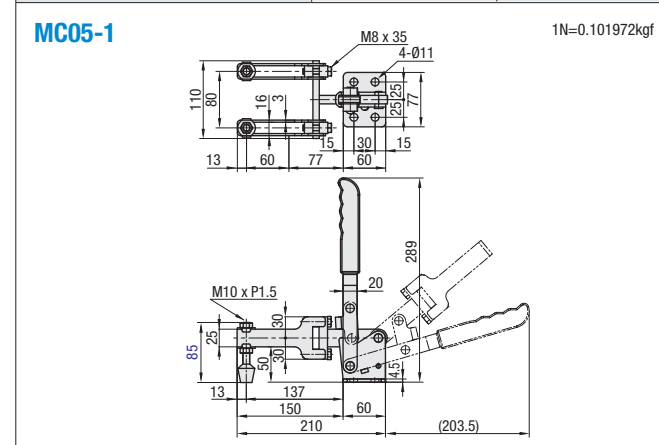

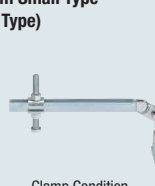
 <p>Clamp Condition</p>	Part Number	<b>MC06-1</b>	 <p>Clamp Condition</p>	Part Number	<b>LN2BS</b>
	Body Material	1018 Carbon Steel or Equivalent		Body Material	1018 Carbon Steel or Equivalent
	Surface Treatment	Trivalent Chromate		Surface Treatment	Bright Chromate Plating
	Tightening Force (N)	1000~3700		Tightening Force (N)	294~980
	Weight (g)	1500		Weight (g)	500
	Open-Close Angle of Arm	119°		Open-Close Angle of Arm	140°
	Open-Close Angle of Handle	91°		Open-Close Angle of Handle	90°
	Accessories	Steel Bolt		Accessories	Steel Bolt

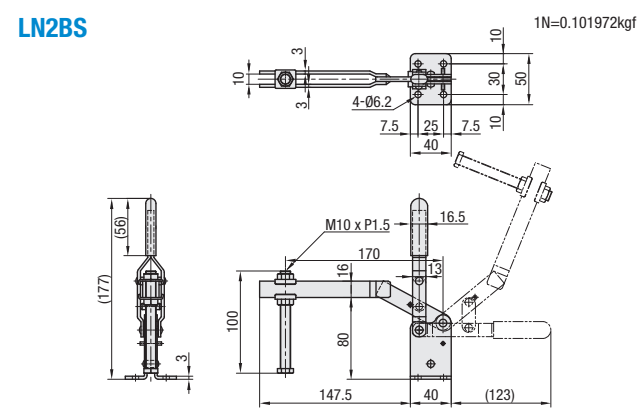
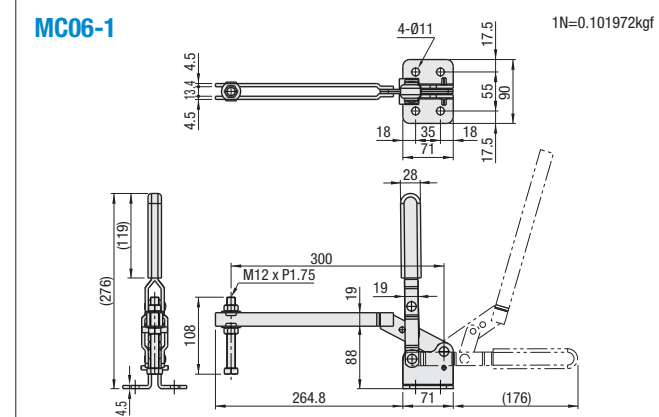

**Part Number Example** **MC06-1** **FTK**

**Application Example**



It can hold both sides of a slot pin.

# Toggle Clamps

Side Push (Flange Base)

Features: MC07-S3 is Stainless Type of MC07-3.

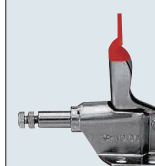
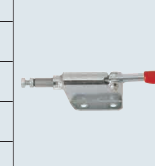
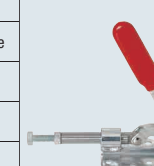
 <p>Clamp Condition *Shaft: Nickel Plating</p>	Part Number	<b>MC07-1</b>	 <p>Clamp Condition *Shaft: Nickel Plating</p>	Part Number	<b>MC07-2</b>	 <p>Clamp Condition *Shaft: Nickel Plating</p>	Part Number	<b>MC07-3</b>	<b>MC07-S3</b>
	Body Material	1018 Carbon Steel or Equivalent		Body Material	1018 Carbon Steel or Equivalent		Body Material	1018 Carbon Steel or Equivalent	304 Stainless Steel
	Surface Treatment	*Trivalent Chromate		Surface Treatment	*Trivalent Chromate		Surface Treatment	*Trivalent Chromate	—
	Stroke (mm)	13.6		Stroke (mm)	10		Stroke (mm)	30	
	Tightening Force (N)	490		Tightening Force (N)	500		Tightening Force (N)	1960	
	Handle Open-Close Angle	91°		Handle Open-Close Angle	66°		Handle Open-Close Angle	147°	
	Weight (g)	70		Weight (g)	100		Weight (g)	370	
	Accessories	Steel Bolt		Accessories	Steel Bolt		Accessories	Steel Bolt	Stainless Steel Bolt

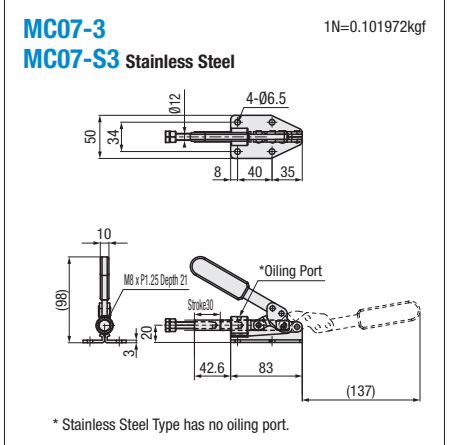
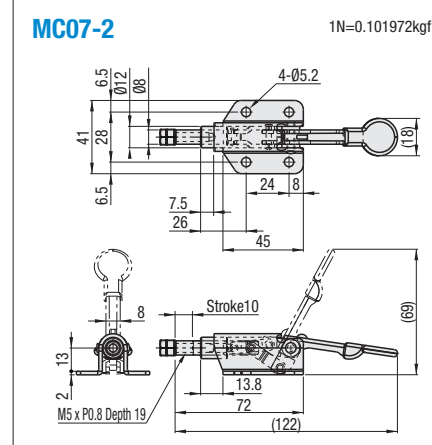
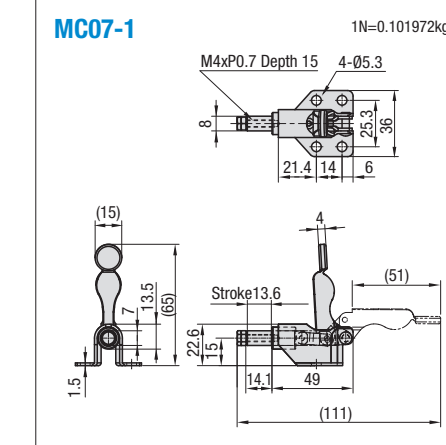

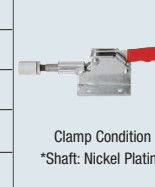
 <p>Clamp Condition *Shaft: Nickel Plating</p>	Part Number	<b>MC07-4</b>	 <p>Clamp Condition *Shaft: Nickel Plating</p>	Part Number	<b>MC07-5</b>
	Body Material	1018 Carbon Steel or Equivalent		Body Material	1018 Carbon Steel or Equivalent
	Surface Treatment	*Trivalent Chromate		Surface Treatment	*Trivalent Chromate
	Stroke (mm)	12		Stroke (mm)	12
	Tightening Force (N)	1568		Tightening Force (N)	1600
	Handle Open-Close Angle	44°		Handle Open-Close Angle	42°
	Weight (g)	460		Weight (g)	450
	Accessories	Steel Bolt		Accessories	Steel Bolt

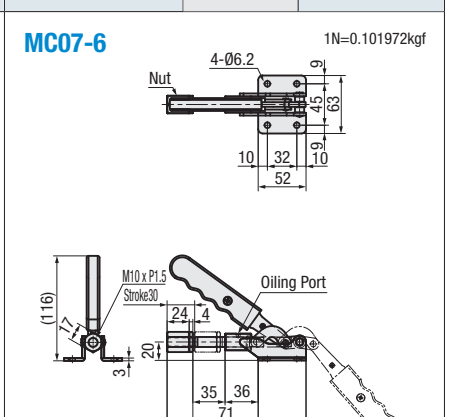
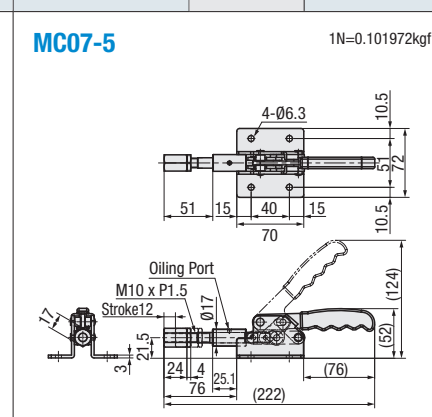
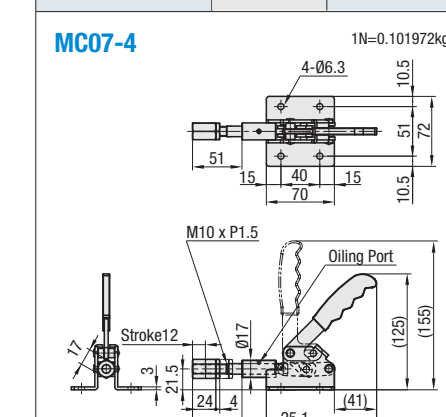

**Part Number Example** **MC07-3**

**Application Example**

