





# Toggle Clamps

## Hold Down, Horizontal Standard Handle (Straight Base)

 Clamp Condition	Part Number	<b>MC01-1S</b>	 Clamp Condition	Part Number	<b>MC01-2S</b>
	Body Material	1018 Carbon Steel or Equivalent		Body Material	1018 Carbon Steel or Equivalent
	Surface Treatment	Trivalent Chromate		Surface Treatment	Trivalent Chromate
	Tightening Force (N)	264.6		Tightening Force (N)	264.6
	Weight (g)	30		Weight (g)	35
	Open-Close Angle of Arm	90°		Open-Close Angle of Arm	90°
	Open-Close Angle of Handle	73°		Open-Close Angle of Handle	73°
Accessories	*Nylon Bolt	Accessories	*Nylon Bolt		

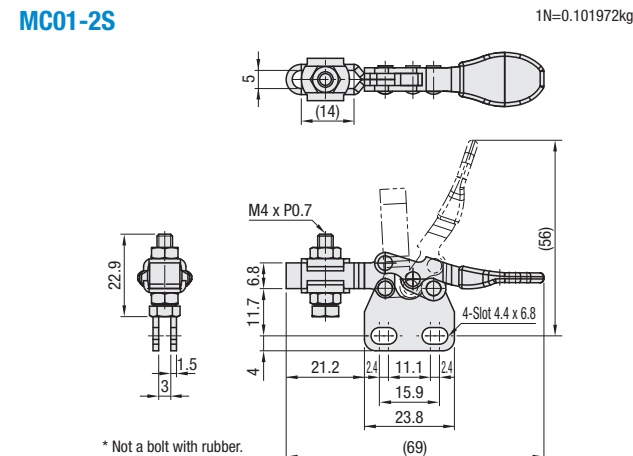
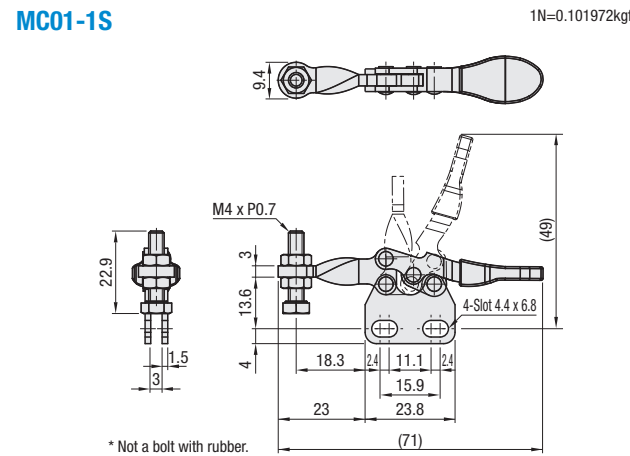

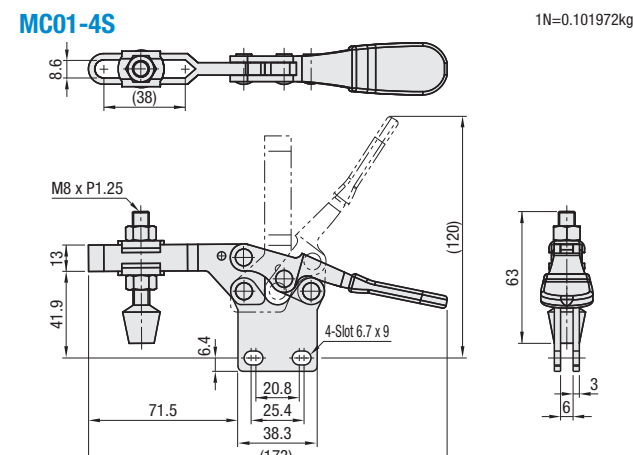
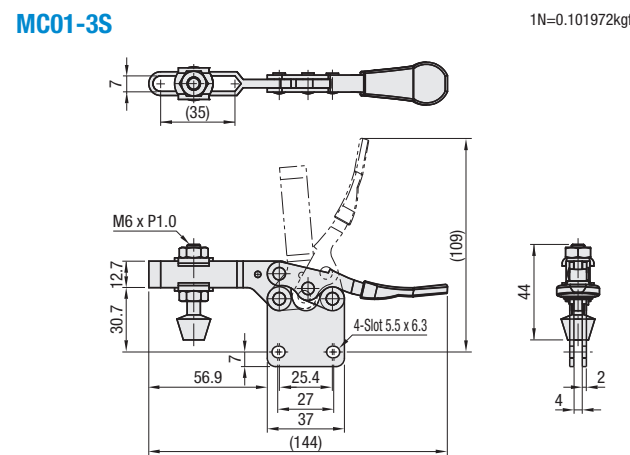

 Clamp Condition	Part Number	<b>MC01-3S</b>	 Clamp Condition	Part Number	<b>MC01-4S</b>
	Body Material	1018 Carbon Steel or Equivalent		Body Material	1018 Carbon Steel or Equivalent
	Surface Treatment	Trivalent Chromate		Surface Treatment	Trivalent Chromate
	Tightening Force (N)	882		Tightening Force (N)	2352
	Weight (g)	130		Weight (g)	265
	Open-Close Angle of Arm	80°		Open-Close Angle of Arm	90°
	Open-Close Angle of Handle	73°		Open-Close Angle of Handle	65°
Accessories	Bolt with Rubber Material: NBR Nitrile Rubber Hardness: Shore A70	Accessories	Bolt with Rubber Material: NBR Nitrile Rubber Hardness: Shore A70		





Part Number Example **MC01-1S**

# Toggle Clamps

## Hold Down, Horizontal Long Handle (Flange Base)

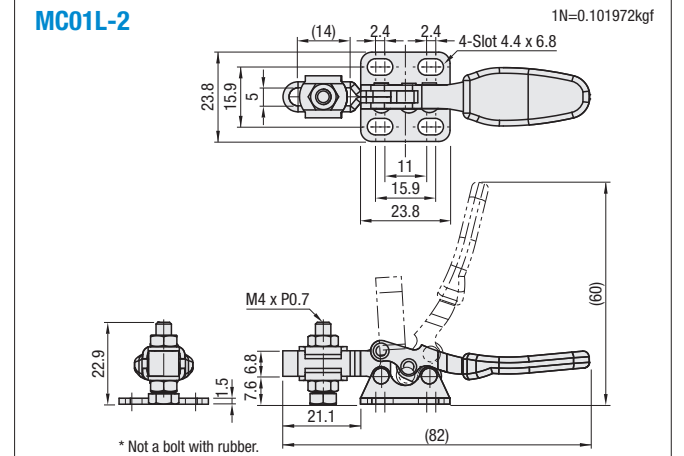
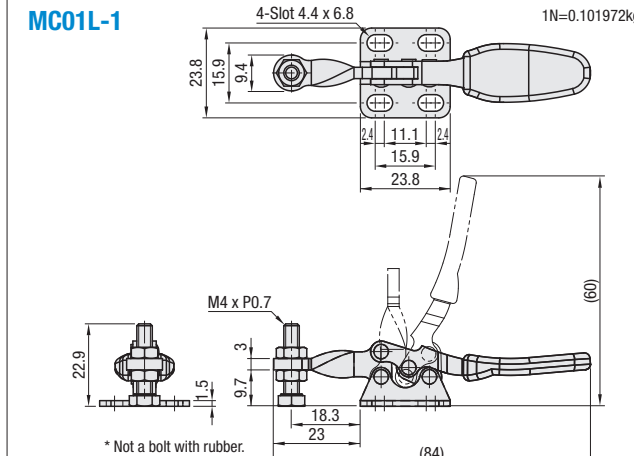
 Clamp Condition	Part Number	<b>MC01L-1</b>	 Clamp Condition	Part Number	<b>MC01L-2</b>
	Body Material	1018 Carbon Steel or Equivalent		Body Material	1018 Carbon Steel or Equivalent
	Surface Treatment	Trivalent Chromate		Surface Treatment	Trivalent Chromate
	Tightening Force (N)	264.6		Tightening Force (N)	264.6
	Weight (g)	35		Weight (g)	40
	Open-Close Angle of Arm	90°		Open-Close Angle of Arm	90°
	Open-Close Angle of Handle	73°		Open-Close Angle of Handle	73°
Accessories	*Nylon Bolt	Accessories	*Nylon Bolt		



 Clamp Condition	Part Number	<b>MC01L-3</b>
	Body Material	1018 Carbon Steel or Equivalent
	Surface Treatment	Trivalent Chromate
	Tightening Force (N)	882
	Weight (g)	140
	Open-Close Angle of Arm	80°
	Open-Close Angle of Handle	73°
Accessories	Bolt with Rubber Material: NBR Nitrile Rubber Hardness: Shore A70	

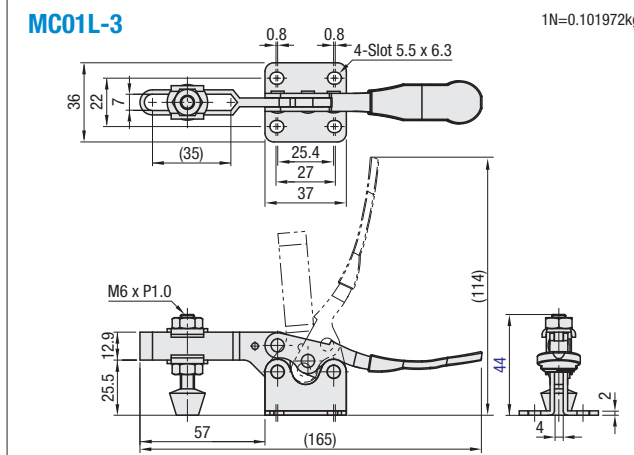

Part Number Example **MC01L-1**

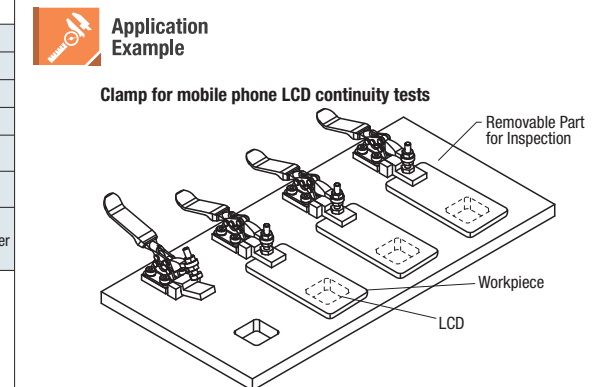

### Long Handles Features (Comparison with Conventional Products)

