

Flat Belt Conveyor Heavy Duty

Center Drive, 3-Groove Frame (Pulley Dia. 30mm)

CE
Compliant

Features: Up to 90W, Medium distance (up to 6m) transfer suited conveyor. The center drive is suitable for "Conveyor to Conveyor" transfer.

Flat Belt Conveyor Heavy Duty – Center Drive, 3-Groove Frame (Pulley Dia. 30mm)

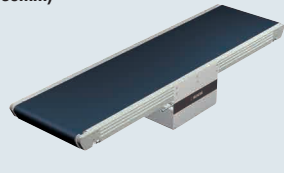

CVSX 60W/90W Motor Type

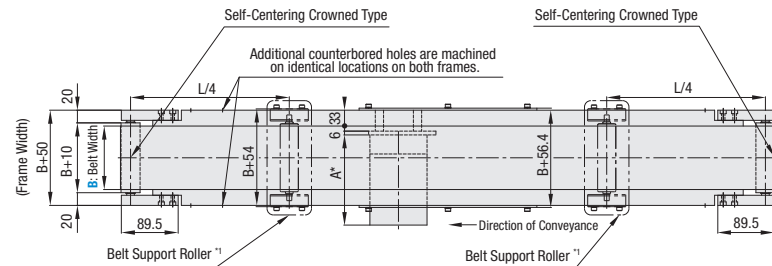

	Frame	Motor Cover	Pulley Holder
Material	Aluminum	Steel	1018 Carbon Steel Equivalent
Surface Treatment	Clear Anodize	Paint	Paint

Frame Cross Section and Enlarged View (Symmetrical)

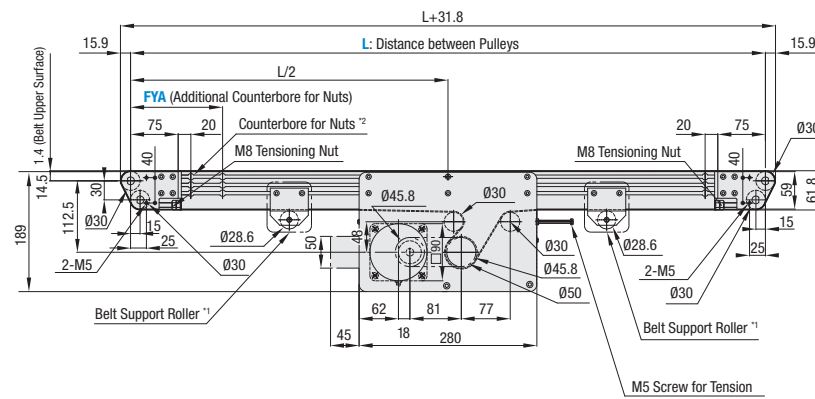
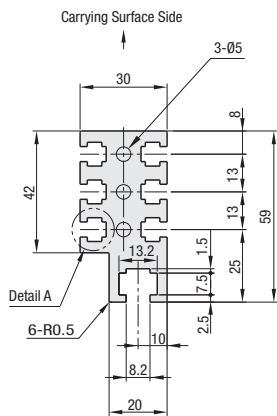

- *1 When L≥4005, belt support rollers are mounted in the diagram locations. The layout is as shown in the diagram at the time of shipping but the drive section and belt support rollers can be moved.
- *2 When L≤525, there will be no counterbored hole for nuts. However, each slot has 4 pre-inserted nuts provided.
- Ⓢ The dimensions in the diagram are for Belt Specifications H (0.9mm thick). Take note that belt thickness varies by Belt Specifications.

Ⓢ Compatible with JIS standard hex nuts.

Motor Specifications

Output (W)	Motor		Reduction Ratio	Length A1
	Specification	Manufacturer		
60W	Constant Speed Motor	Panasonic	5-180	180.0
		Oriental	5-180	185.0
		Taiwanese	5-75	182.6
	Variable Speed Motor	Oriental	90-180	191.6
		Taiwanese	5-75	194.6
		Taiwanese	90-180	203.6
90W	Constant Speed Motor	Panasonic	5-180	195.0
		Oriental	5-180	200.0
		Taiwanese	5-75	197.6
	Variable Speed Motor	Oriental	90-180	204.6
		Taiwanese	5-180	230.0
		Taiwanese	5-75	209.6

Conveying Capacity

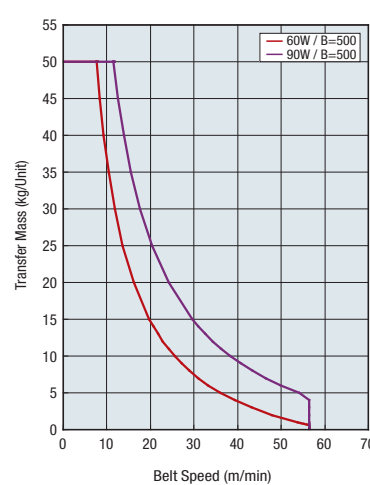

*Reference Value may differ by selected Belt.

Gearhead Reduction Ratio

*May decrease depending on load condition.

Gearhead Reduction Ratio	Belt Speed (m/min)	
	50Hz	60Hz
5	47.1	56.5
7.5	31.4	37.7
9	26.2	31.4
12.5	18.8	22.6
15	15.7	18.8
18	13.1	15.7
25	9.4	11.3
30	7.9	9.4
36	6.5	7.9
50	4.7	5.7
60	3.9	4.7
75	3.1	3.8
90	2.6	3.1
100	2.4	2.8
120	2.0	2.4
150	1.6	1.9
180	1.3	1.6

Flat Belt Conveyor Heavy Duty

Center Drive, 3-Groove Frame (Pulley Dia. 30mm), continued

Conveyor Resource Site:
http://www.misumiusa.com/conveyor/
Conveyor Selection, Design Your Own Conveyor Kit, & Maintenance Parts Search

Part Number	Width B (mm)	Length L 5mm Increment	Motor		Gearhead Reduction Ratio	Belt Specification	FYA (Additional Counterbores) 5mm Increment	Motor Manufacturer Selection			
			Output (W)	Voltage (V)							
CVSX	100 200 300 400 500	480-6000	60 90	(Single-Phase) TA100 TA110 TA115 TA200 TA220 TA230	IM (Constant Speed Motor) SCM (Variable Speed Motor)	5 7.5 9 12.5 15 18 25 30 36 50 60 75 90 100 120 150 180	H (General Purpose, Green) W (General Purpose, White) G (For Sliding, Green) S (For Sliding, White) D (Static Conductive) F (Food Grade) O (Oil Resistant) N (Non-Stick Food Grade) J (No Belt) * For belts other than the above, select from Belt Specification below.	105-FYA-L-105 * When not specified, there will be no additional counterbores.	A (Panasonic Motor) B (Oriental Motor) C (Taiwanese Motor) *SCM (Variable Speed Motor) is not selectable for A.		
				(Three-Phase) SA200 SA220 SA230						IM (Constant Speed Motor)	
						NV (No Motor)	NM (No Motor)	NH (No Gearhead)			R (No Motor, Gearhead)

- Ⓢ Connect the motor so that the belt rotates in the direction of conveyance.
- Ⓢ Workpiece weighing over 10kg/unit might deform belt base plate.

Ⓢ When the unit length (L dim.) is 2000mm or less, this will be delivered complete. For a unit over 2000mm, the frame is delivered in sections and the customer is to assemble according to the included assembly instructions. The assembly procedure manual can also be downloaded from our Conveyor Selection web site.

- Ⓢ When "No motor, gearhead" is selected, the motor mounting hole pitch will vary depending on the motor's power rating. Please see Technical Information in our Conveyor Selection web site for the dimension details.
- Ⓢ When "No motor, gearhead" is selected, this unit will be delivered unassembled. The customer is to assemble the unit according to the included assembly instructions. See our Conveyor Selection site for assembly procedures and packaging details.

Belt Specification	Standard Belt	Optional Belt 1	Optional Belt 2	No Belt
General Purpose	H (Green), W (White), HG (Green)	—	HY (Yellow Green), HBN (Sky Blue)	J (No Belt)
For Sliding	G (Green), S (White)	—	—	
For Inclined Transfer	LG (Green), LW (White)	—	—	
Grip Type	—	GG (Green), GW (White)	GSN (Green)	
Oil Resistant	O (Navy Blue), OH (Green), OG (Green)	OW (White)	ON (White)	
Non-Stick Food Grade	N (White), NS (White)	NB (Sky Blue), NBG (Lime Green), HH (Green), HW (White)	NWN (White), NSN (Sky Blue), NGN (Lime Green), HBG (Green), HBW (White), BW (White)	
Food Grade	F (White)	KW (White), KSB (Sky Blue), PHB (Sky Blue)	PHN (Sky Blue), PWN (Sky Blue), KWN (White)	
Static Conductive	D (Black), DS (Black)	—	DG (Black)	

Ⓢ If using Optional Belts, please select motor manufacturer A or B (Motor C is applicable for Standard Belt only).

Part Number	B	Available Types																						
		L480-600	L605-800	L805-1000	L1005-1200	L1205-1400	L1405-1600	L1605-1800	L1805-2000	L2005-2200	L2205-2400	L2405-2600	L2605-2800	L2805-3000	L3005-3250	L3255-3500	L3505-3750	L3755-4000	L4005-4250	L4255-4500	L4505-5000	L5005-5500	L5505-6000	
CVSX	100	•	•	•	•	•	•	•	•	•	•	•	•	•	•	•	•	•	•	•	•	•	•	•
	200	—	•	•	•	•	•	•	•	•	•	•	•	•	•	•	•	•	•	•	•	•	•	•
	300	—	—	•	•	•	•	•	•	•	•	•	•	•	•	•	•	•	•	•	•	•	•	•
	400	—	—	—	•	•	•	•	•	•	•	•	•	•	•	•	•	•	•	•	•	•	•	•
	500	—	—	—	—	•	•	•	•	•	•	•	•	•	•	•	•	•	•	•	•	•	•	•

Part Number Example

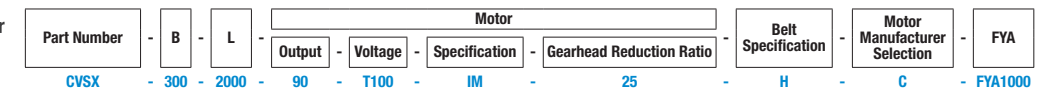

Part Number Alterations

- Specify Drive Section Position
- Brackets for Speed Controller Included
- Post-Assembly Insertion Nuts Included
- Motors with Electromagnetic Brake
- Stands (Legs)

For details of alterations, see P1276.