

Guided Flat Belt Conveyor Full Belt Type

Guided Belt to Prevent Lateral Movement 3-Groove Frame (Pulley Dia. 50mm)

CE Compliant

Features: Conveyor with full width belt that the entire surface can be used for transporting. The belt with the guide prevents lateral movement.

Guided Flat Belt Conveyor Full Belt Type – Guided Belt to Prevent Lateral Movement 3-Groove Frame (Pulley Dia. 50mm)

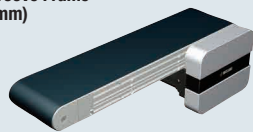

CVSFD 6W Motor Type

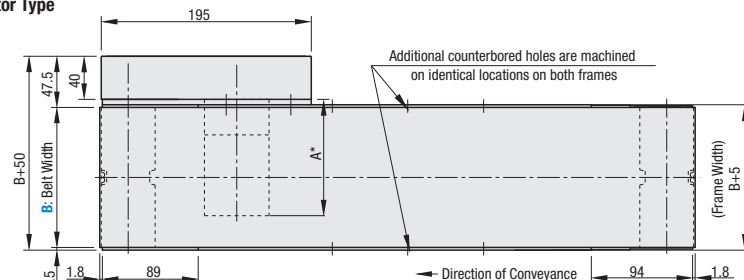

	Frame	Motor Cover	Pulley Holder (1)	Pulley Holder (2)
Material	Aluminum	Aluminum	5052 Aluminum Alloy	1018 Carbon Steel
Surface Treatment	Clear Anodize	Paint	Clear Anodize	Trivalent Chromate

Frame Cross Section and Enlarged View (Symmetrical)

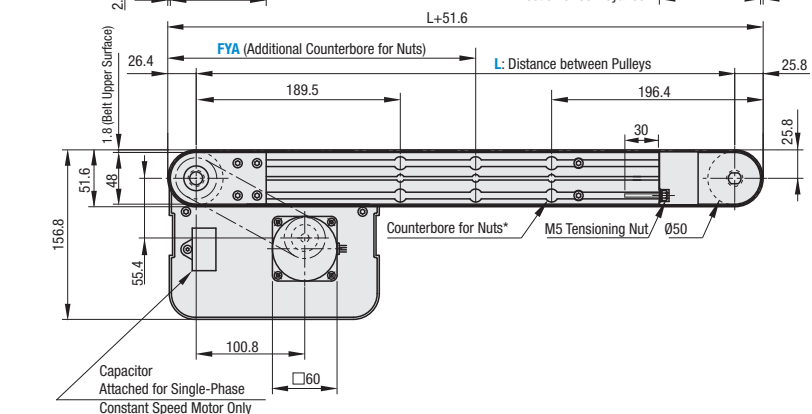
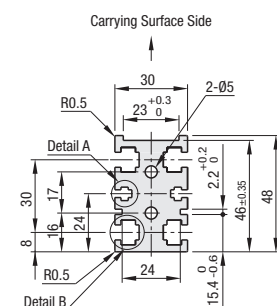

25W Motor Type

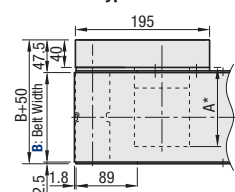

40W Motor Type

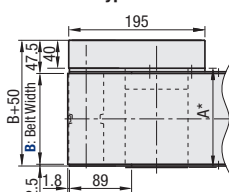

*When L<415, counterbores for the nuts will not be provided. However, each slot has 4 pre-inserted nuts provided.
 Ⓢ The dimensions in the diagram are for Belt Specifications H (0.8mm thick). Take note that belt thickness varies by Belt Specifications.
 Ⓢ The "Detail B" of the frame is used for pulley holder mounting. The nuts cannot be moved to this area.

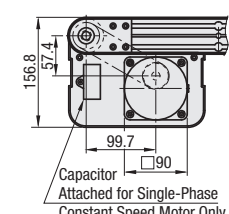
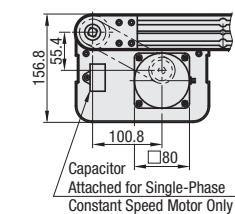

Ⓢ Compatible with JIS standard hex nuts.

Motor Specifications

Output (W)	Motor Specification	Motor Manufacturer	Reduction Ratio	Motor Length (A)
6W	Constant Speed Motor	Panasonic	12.5-25	101.0
			30-180	108.0
		Oriental	12.5-25	105.0
	30-180		115.0	
	Taiwanese		12.5-75	119.7
	25W	Constant Speed Motor	Panasonic	5-18
25-180				127.5
Oriental			5-75	129.0
		90-180	136.0	
		Taiwanese	5-18	127.0
Variable Speed Motor		Oriental	25-180	137.5
	5-75		139.5	
	Taiwanese	90-180	146.5	

Output (W)	Motor Specification	Motor Manufacturer	Reduction Ratio	Motor Length (A)
40W	Constant Speed Motor	Panasonic	5-180	142.0
			5-18	147.0
		Oriental	25-180	165.0
	5-75		164.6	
	Taiwanese		90-180	173.6
	Variable Speed Motor	Oriental	5-18	157.0
25-180			175.0	
Taiwanese		5-75	175.1	
		Taiwanese	90-180	184.1

Conveying Capacity

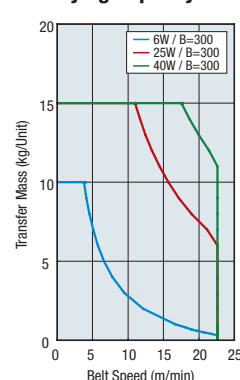

*Reference Value may differ by selected Belt.

Gearhead Reduction Ratio

*May decrease depending on load condition.

Gearhead Reduction Ratio	Belt Speed (m/min)	
	50Hz	60Hz
5	47.1	56.5
7.5	31.4	37.7
9	26.2	31.4
12.5	18.8	22.6
15	15.7	18.8
18	13.1	15.7
25	9.4	11.3
30	7.9	9.4
36	6.5	7.9
50	4.7	5.7
60	3.9	4.7
75	3.1	3.8
90	2.6	3.1
100	2.4	2.8
120	2.0	2.4
150	1.6	1.9
180	1.3	1.6

Guided Flat Belt Conveyor Full Belt Type Guided Belt to Prevent Lateral Movement 3-Groove Frame (Pulley Dia. 50mm), continued

Conveyor Resource Site:
<http://www.misumiusa.com/conveyor/>
 Conveyor selection, Design your own kit, & Maintenance parts search.

Part Number	Width B 10mm Increment	Length L 5mm Increment	Motor				Belt Specification	FYA (Additional Counterbores) 5mm Increment	Motor Manufacturer Selection Ⓢ Prices vary by manufacturer.
			Output (W)	Voltage (V)	Specification	Gearhead Reduction Ratio			
CVSFD	80-300	320-2000	6 25 40	(Single-Phase) TA100 TA110 TA115 TA200 TA220 TA230	IM (Constant Speed Motor) SCM (Variable Speed Motor)	5 7.5 9 12.5 15 18 25 30 36 50 60 75 90 100 120	H (General Purpose, Green) W (General Purpose, White) G (For Sliding, Green) S (For Sliding, White) D (Static Conductive) F (For Food, White) O (Oil Resistant) N (Non-Stick Food Grade) J (No Belt)	240<FYA<L-220 *When not specified, there will be no additional counterbores.	A (Panasonic Motor) B (Oriental Motor) C (Taiwanese Motor) * SCM (Variable Speed Motor) is not selectable for A. R (No Motor, Gearhead)
			25 40	(Three-Phase) SA200 SA220 SA230	IM (Constant Speed Motor)	Ⓢ 5-9 not applicable for 6W Motor			
			6 25 40	NV (No Motor)	NM (No Motor)	NH (No Gearhead)			

- Ⓢ Connect the motor so that the belt rotates in the direction of conveyance.
- Ⓢ When "No motor, gearhead" is selected, the motor mounting hole pitch will vary depending on the motor's power rating. Please see Technical Information in our Conveyor Selection web site for the dimension details.
- Ⓢ When "No motor, gearhead" is selected, this unit will be delivered unassembled. The customer is to assemble the unit according to the included assembly instructions. See our Conveyor Selection site for assembly procedures and packaging details.
- Ⓢ Note that warpage might occur on the guided belt depending on the number of plies (thickness).

Belt Specification	Standard Belt	Optional Belt 1	Optional Belt 2	No Belt
General Purpose	H (Green), W (White)	—	—	J (No Belt)
For Sliding	G (Green), S (White), SN (White)	—	—	
For Inclined Transfer	—	—	—	
Grip Type	—	—	GG (Green), GW (White)	
Oil Resistant	O (Green)	OW (White)	—	
Non-Stick Food Grade	N (White)	NB (Sky Blue), NBG (Lime Green), HH (Green), HW (White)	HBG (Non-Stick, Green)	
Food Grade	—	KW (White), KSB (Sky Blue), PHB (Sky Blue)	—	
Static Conductive	D (Black)	—	—	

Ⓢ If using Optional Belts, please select motor manufacturer A or B (Motor C is applicable for Standard Belt only).

Part Number	B	Available Types																	
		L320-400	L405-500	L505-600	L605-700	L705-800	L805-900	L905-1000	L1005-1100	L1105-1200	L1205-1300	L1305-1400	L1405-1500	L1505-1600	L1605-1700	L1705-1800	L1805-1900	L1905-2000	
CVSFD	80-100	•	•	•	•	•	•	•	•	•	•	•	•	•	•	•	•	•	•
	110-150	•	•	•	•	•	•	•	•	•	•	•	•	•	•	•	•	•	•
	160-200	—	•	•	•	•	•	•	•	•	•	•	•	•	•	•	•	•	•
	210-250	—	—	•	•	•	•	•	•	•	•	•	•	•	•	•	•	•	•
	260-300	—	—	—	•	•	•	•	•	•	•	•	•	•	•	•	•	•	•

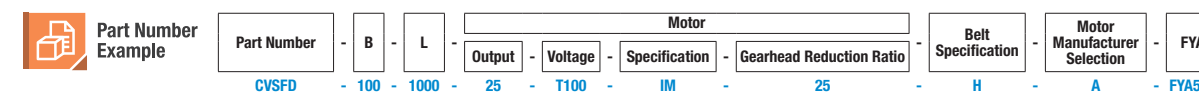

Part Number Alterations

Motor Position Reversed
Motor Cover with Window
Brackets for Speed Controller Included
Post-Assembly Insertion Nuts Included
Motor with Terminal Box
Stands (Legs)

For details of alterations, see P.1276.