

Flat Belt Conveyors

Center Drive, 2-Groove Frame (Pulley Dia. 30mm)

Features: A Flat Belt Conveyor with adjustable drive section position. Belt tension can be adjusted at the center drive section, and the overall length does not change after tension adjustment. With the addition of tapped holes for pulley holders, mounting of optional parts becomes easier than that with CVSN.

Flat Belt Conveyors – Center Drive, 2-Groove Frame (Pulley Dia. 30mm)



	Frame	Motor Cover (1)	Motor Cover (2)	Pulley Holder
Material	Aluminum	Aluminum	Low Carbon Steel	Aluminum
Surface Treatment	Clear Anodize	Paint	Paint	Paint

Frame Cross Section and Enlarged View (Symmetrical)

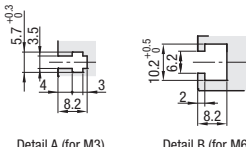
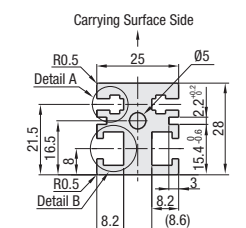

Compatible with JIS standard hex nuts.

CVGN 6W Motor Type

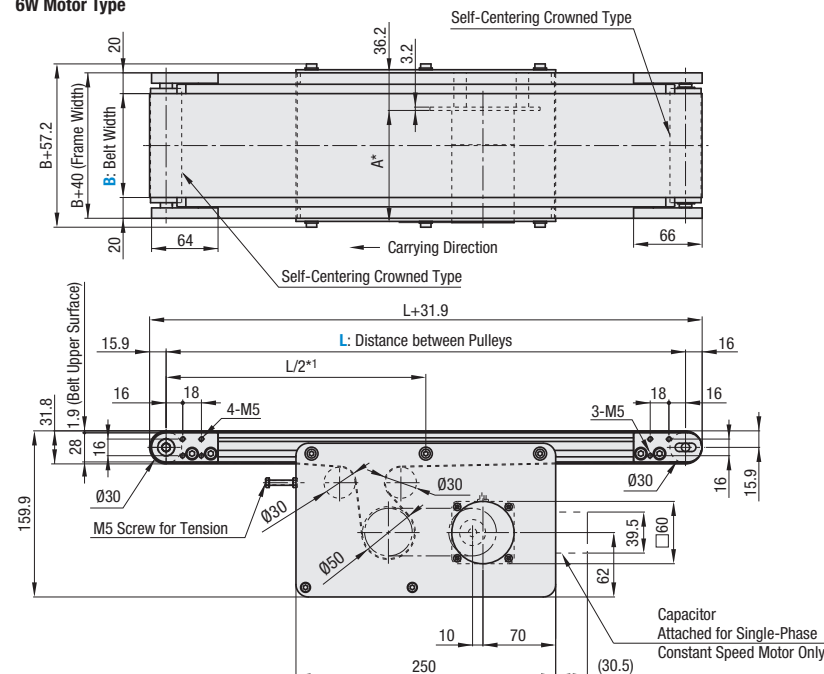

25W Motor Type

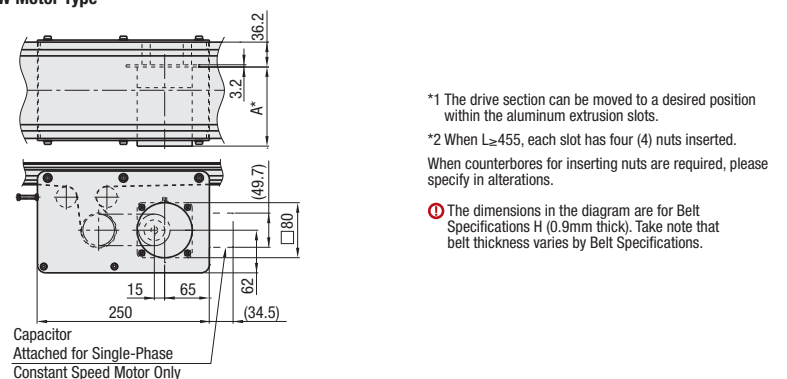

*1 The drive section can be moved to a desired position within the aluminum extrusion slots.
 *2 When $L \geq 455$, each slot has four (4) nuts inserted. When counterbores for inserting nuts are required, please specify in alterations.

The dimensions in the diagram are for Belt Specifications H (0.9mm thick). Take note that belt thickness varies by Belt Specifications.

Motor Specifications

Output (W)	Specification	Motor		Reduction Ratio	Motor Length (A)
		Manufacturer	Manufacturer		
6W	Constant Speed Motor	Panasonic		12.5-25	101.0
		Oriental		30-180	108.0
		Taiwanese		12.5-18	105.0
	Variable Speed Motor	Oriental		25-180	115.0
		Taiwanese		12.5-75	114.7
		Taiwanese		90-180	120.7
25W	Constant Speed Motor	Panasonic		5-180	115.0
		Oriental		5-18	117.0
		Taiwanese		25-180	127.5
	Variable Speed Motor	Taiwanese		5-75	129.0
		Oriental		90-180	136.0
		Taiwanese		5-18	127.0
				25-180	137.5
				5-75	139.5
				90-180	146.5

Conveying Capacity

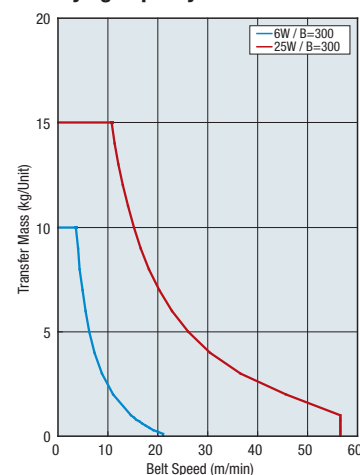

*Reference Value may differ by selected Belt.

Gearhead Reduction Ratio

*May decrease depending on load condition.

Gearhead Reduction Ratio	Belt Speed (m/min)	
	50Hz	60Hz
5	47.1	56.5
7.5	31.4	37.7
9	26.2	31.4
12.5	18.8	22.6
15	15.7	18.8
18	13.1	15.7
25	9.4	11.3
30	7.9	9.4
36	6.5	7.9
50	4.7	5.7
60	3.9	4.7
75	3.1	3.8
90	2.6	3.1
100	2.4	2.8
120	2.0	2.4
150	1.6	1.9
180	1.3	1.6

Flat Belt Conveyors

Center Drive, 2-Groove Frame (Pulley Dia. 30mm), continued

Conveyor Resource Site:
<http://www.misumiusa.com/conveyor/>
 Conveyor selection, Design your own kit, & Maintenance parts search.

Part Number	Width B 1mm Increment	Length L 5mm Increment	Motor				Belt Specification	Motor Manufacturer Selection				
			Output (W)	Voltage (V)	Specification	Gearhead Reduction Ratio						
CVGN	30-300	355-2000	6 25	(Single-Phase) TA100 TA110 TA115 TA200 TA220 TA230	IM (Constant Speed Motor) SCM (Variable Speed Motor)	5 7.5 9 12.5 15 18 25 30 36 50 60 75 90 100 120 150 180	H (General Purpose, Green) W (General Purpose, White) G (For Sliding, Green) S (For Sliding, White) D (Static Conductive) F (Food Grade) O (Oil Resistant) N (Non-Stick Food Grade) J (No Belt) * For belts other than the above, select from Belt Specification below.	A (Panasonic Motor) B (Oriental Motor) C (Taiwanese Motor) * SCM (Variable Speed Motor) is not selectable for A.				
									25	(Three-Phase) SA200 SA220 SA230	IM (Constant Speed Motor)	5-9 not applicable for 6W Motor

- Connect the motor so that the belt rotates in the direction of conveyance.
- When "No motor, gearhead" is selected, the motor mounting hole pitch will vary depending on the motor's power rating. Please see Technical Information in our Conveyor Selection web site for the dimension details.
- When "No motor, gearhead" is selected, this unit will be delivered unassembled. The customer is to assemble the unit according to the included assembly instructions. See our Conveyor Selection site for assembly procedures and packaging details.

Belt Specification	Standard Belt	Optional Belt 1	Optional Belt 2	No Belt
General Purpose	H (Green), W (White), HG (Green)	—	HY (Yellow Green), HBN (Sky Blue)	J (No Belt)
For Sliding	G (Green), S (White),	—	—	
For Inclined Transfer	LG (Green), LW (White),	—	—	
Grip Type	—	GG (Green), GW (White)	GSN (Green)	
Oil Resistant	O (Navy Blue), OH (Green), OG (Green)	OW (White)	ON (White)	
Non-Stick Food Grade	N (White), NS (White)	NB (Sky Blue), NBG (Lime Green), HH (Green), HW (White)	NWN (White), NSN (Sky Blue), NGN (Lime Green), HBG (Green), HBW (White), BW (White)	
Food Grade	F (White)	KW (White), KSB (Sky Blue), PHB (Sky Blue)	PHN (Sky Blue), PWN (Sky Blue), KWN (White)	
Static Conductive	D (Black), DS (Black)	—	DG (Black)	

If using Optional Belts, please select motor manufacturer A or B (Motor C is applicable for Standard Belt only).

Part Number	B	Available Types																	
		L355-400	L405-500	L505-600	L605-700	L705-800	L805-900	L905-1000	L1005-1100	L1105-1200	L1205-1300	L1305-1400	L1405-1500	L1505-1600	L1605-1700	L1705-1800	L1805-1900	L1905-2000	
CVGN	30-50	•	•	•	•	•	•	•	•	•	•	•	•	•	•	•	•	•	•
	60-100	•	•	•	•	•	•	•	•	•	•	•	•	•	•	•	•	•	•
	110-150	—	—	•	•	•	•	•	•	•	•	•	•	•	•	•	•	•	•
	160-200	—	—	—	•	•	•	•	•	•	•	•	•	•	•	•	•	•	•
	210-250	—	—	—	—	•	•	•	•	•	•	•	•	•	•	•	•	•	•
	260-300	—	—	—	—	—	•	•	•	•	•	•	•	•	•	•	•	•	•

Part Number Example

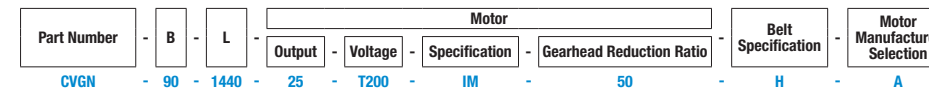

Part Number Alterations

- Specify Drive Section Position
- Additional Counterbores
- Roller Edge
- Motor Cover with Window
- Brackets for Speed Controller Included
- Post-Assembly Insertion Nuts Included
- Motors with Electromagnetic Brake
- Stands (Legs)

For details of alterations, see P.1276.