

Couplings (Oldham)

Blue Set Screw / Clamping / Green Short Clamping

Couplings – Oldham, Blue Set Screw



RoHS10

CPO

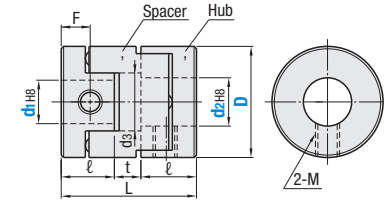

Operating Temperature -20~80°C

The lateral, angular, and axial misalignment values shown are for each occurring individually. When more than one misalignments are occurring simultaneously, the allowable maximum value of each will be reduced by 1/2.

For the selection criteria and alignment procedures, see P.1091, 1093.

Parts	Material	Surface Treatment	Accessories
Hub	Aluminum Alloy	Clear Anodize	Set Screw
Spacers	Polyacetal	—	

Couplings – Oldham, Clamping



RoHS10

CPOC

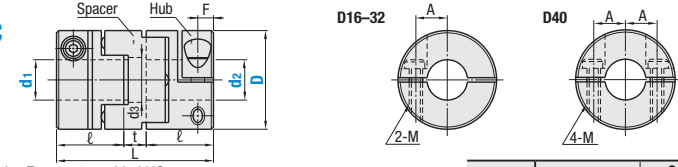

Operating Temperature -20~80°C

The lateral, angular, and axial misalignment values shown are for each occurring individually. When more than one misalignments are occurring simultaneously, the allowable maximum value of each will be reduced by 1/2.

For the selection criteria and alignment procedures, see P.1091, 1093.

Parts	Material	Surface Treatment	Accessories
Hub	Aluminum Alloy	Clear Anodize	Hex Socket Head Cap Screw
Spacers	Polyacetal	—	

Couplings – Oldham, Green Short Clamping



RoHS10

CPOCG (Short)

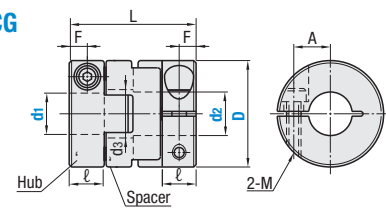

Operating Temperature -20~80°C

The lateral, angular, and axial misalignment values shown are for each occurring individually. When more than one misalignments are occurring simultaneously, the allowable maximum value of each will be reduced by 1/2.

For the selection criteria and alignment procedures, see P.1091, 1093.

Parts	Material	Surface Treatment	Accessories
Hub	Aluminum Alloy	Anodizing	Hex Socket Head Cap Screw
Spacers	Polyacetal	—	

Part Number	Type	D	d ₁ , d ₂ (d ₁ =d ₂)	d _s	L	L	t	F	A	Set Screw / Clamp Screw	
										M	Tightening Torque (N·m)
5.9	CPO	1.5	2	—	8.4	2.5	3	1.25	—	M2	0.3
7.9	CPO	1	2.2.5	—	9.8	2.5	4.8	1.25	—	M2	0.3
9.9	CPO	—	2.3	—	10.4	2.9	4.6	1.5	—	M2	0.3
11.9	CPO	—	3.4	—	14.5	3.9	6.7	2	—	M3	0.7
16	CPO	—	3.4	—	7	18	7	4	3.5	M3	0.7
20	CPO	—	4.5	—	9	23	9	5	4.5	M4	1.7
25	CPO	—	5.6	—	11	28	11	6	5.5	M5	4
32	CPO	—	8	—	14.5	33	13	7	6.5	M6	7
*40	CPO	—	10	—	17	32	14	4	7	M6	7
*43	CPO	—	8	—	21.7	52	16.5	19	7.1	M5	4
*53	CPO	—	10	—	25.7	58.3	19.5	19.3	7.5	M6	7
*57	CPO	—	15	—	26	76.2	26.9	22.4	9.9	M8	15
*73	CPO	—	18	—	35.3	75.5	25	25.5	12.2	M8	15
16	CPOC	—	5	—	7	29	12.5	4	3	M2.5	1
20	CPOC	—	6	—	9	33	14	5	6.5	M2.5	1
25	CPOC	—	6	—	11	39	16.5	6	3.8	M3	1.5
32	CPOC	—	8	—	14.5	45	19	7	4.5	M4	2.5
*40	CPOC	—	10	—	17	50	23	4	7	M5	4
*43	CPOC	—	8	—	21.7	52	16.5	19	5.8	M5	8
*53	CPOC	—	10	—	25.7	58.3	19.5	19.3	6.3	M5	8
*57	CPOC	—	15	—	26	76.2	26.9	22.4	7.7	M6	13
*73	CPOC	—	18	—	35.3	81.5	28	25.5	10	M8	30
*88	CPOC	—	15	—	40.5	97	33.5	30	12	M10	50
*118	CPOC	—	25	—	50.5	138	40.5	57	13	M12	90
12	CPOCG	—	3	—	6	14.9	5	—	2.5	M2	0.5
16	CPOCG	—	3	—	8	21	—	—	5	M2.5	1
20	CPOCG	—	5	—	10	22.1	7	—	3.5	M2.5	1
25	CPOCG	—	6	—	14	27.2	8	—	4	M3	1.5
32	CPOCG	—	8	—	18	33.3	10	—	5	M4	2.5
*43	CPOCG	—	8	—	21.7	47	16.5	14	5.8	M5	8
*53	CPOCG	—	10	—	25.7	53.1	19.5	14.1	6.3	M5	8
*57	CPOCG	—	15	—	26	56.8	26.9	3	7.7	M6	13
*73	CPOCG	—	18	—	35.3	75.5	28	19.5	10	M8	30

*D40, D43, D53, D57, D73, D88, and D118 come with a black spacer.

Couplings (Oldham)

Blue Set Screw / Clamping / Green Short Clamping, *continued*

Part Number	Type	D	Allow. Torque (N·m)	Angular Misalign. (°)	Lateral Misalign. (mm)	Static Torsional Spring Constant (N·m/rad)	Max Rotational Speed (r/min)	Moment of Inertia (Kg·m ²)	Mass (g)
5.9	CPO	1.5	0.2	1.5	0.5	5	22000	7.4×10 ⁻⁸	0.5
7.9			0.5		0.7	10	20000	8.4×10 ⁻⁹	0.9
9.9			0.7		0.9	25	18000	2.4×10 ⁻⁸	1.7
11.9			0.8		1	55	15000	6.3×10 ⁻⁸	3
16			0.7		1	31	39000	3.2×10 ⁻⁷	7
20			1.2		1.5	60	31000	1.0×10 ⁻⁶	14
25			2		2	140	25000	3.0×10 ⁻⁶	27
32			4.5		2.5	280	19000	9.5×10 ⁻⁶	50
40			9		3	540	15000	2.3×10 ⁻⁵	80
43			12.5		3	1200	8000	3.7×10 ⁻⁵	135
53	CPOC	1.5	20	1.5	3.2	1400	7000	1.0×10 ⁻⁴	228
57			34		3.5	2600	6000	1.8×10 ⁻⁴	345
73			60		3.5	4800	4500	4.5×10 ⁻⁴	567
16			0.7		1	31	39000	5.8×10 ⁻⁷	12
20			1.2		1.5	60	31000	1.5×10 ⁻⁶	19
25			2		2	140	25000	4.4×10 ⁻⁶	36
32			4.5		2.5	280	19000	1.4×10 ⁻⁵	69
40			9		3	540	15000	4.1×10 ⁻⁵	130
43			12.5		3	1200	8000	3.4×10 ⁻⁵	127
53			20		3.2	1400	7000	9.1×10 ⁻⁵	217
57	34	3.5	2600	6000	1.6×10 ⁻⁴	329			
73	65	3.5	2000	4500	5.4×10 ⁻⁴	670			
88	105	4	2500	4500	1.2×10 ⁻³	1240			
118	200	4.5	6300	3500	6.5×10 ⁻³	2600			
12	CPOCG	2	0.2	2	0.6	9	52000	7.1×10 ⁻⁸	3
16			0.4		1	30	39000	3×10 ⁻⁷	8
20			0.7		1.3	47	31000	7.4×10 ⁻⁷	13
25			1.2		1.5	85	25000	2.2×10 ⁻⁶	24
32			2.8		2	190	19000	7.3×10 ⁻⁶	48
43			12.5		3	1200	8000	3.0×10 ⁻⁵	114
53			20		3.2	1400	7400	8.3×10 ⁻⁵	197
57			34		3.5	2600	600	1.2×10 ⁻⁴	232
73			60		3.5	4800	4500	4.5×10 ⁻⁴	547

The allowable torque varies depending on temperature. See P.1091

Part Number Example

Part Number - Shaft Bore Dia. d₁ - Shaft Bore Dia. d₂

CPO25 - 8 - 10
 CPOC20 - 6 - 8
 CPOCG16 - 3 - 5

Spacers are available separately P.1112.

Part Number Alterations

Part Number - Shaft Bore Dia. d₁ (LDC) - Shaft Bore Dia. d₂ (RDC) - (LK, RK)

CPO16 - LDC4.5 - RDC5.5
 CPOC25 - 8 - 10 - RK3

Keyway Dimension

Alterations	Shaft Bore Dia.		Keyway							
	CPO	CPOC	CPO	CPOC	CPOCG					
Spec.	1mm Increment		Ordering Code: Shaft Dia. d ₁ , d ₂ , LK, RK							
	3.175, 4.5, 9.525, 12.7, and 15.875 are available sizes.		<table border="1"> <tr><td>8-10</td><td>3</td></tr> <tr><td>10-12</td><td>4</td></tr> <tr><td>12-16</td><td>5</td></tr> </table>			8-10	3	10-12	4	12-16
8-10	3									
10-12	4									
12-16	5									
Code	LDC (Left Shaft)	RDC (Right Shaft)	KL (Left Shaft)	RK (Right Shaft)						

D5.9-11.9, D43-118 are not available.

Shaft Bore Dia. d ₁ , d ₂	b		t		Keyway Dims. b x h
	Dim.	Tolerance	Dim.	Tolerance	
8-10	3	±0.0125	1.4		3×3
11-12	4		1.8	+0.1	4×4
13-17	5	±0.0150	2.3	0	5×5
18-22	6		2.8		6×6
23-30	8		3.3		8×7
31-38	10	±0.0180	3.3		10×8
39-44	12		3.3		12×8
45-50	14		3.8	+0.2	14×9
51-58	16	±0.0215	4.3	0	16×10
59-60	18		4.4		18×11

1114

There's more on the web: misumiusa.com

Check out misumiusa.com for the most current pricing and lead time.

1115