



Conveyor Chute / Angle Adjustment Bracket Single Article

■Features: Chutes with their angle adjustable between 5 to 60 degrees. Plastic type is also available to make the workpiece move smoother and to prevent scratching of the workpiece.



Type		Material	Allowable Load (kgf)	Thickness (t)
Angle Adjustable	30° Angle-Fixed			
CSHWS	CSHYS	304 Stainless Steel	15	1.5
CSHWE	CSHYE	304 Stainless Steel + Stainless Steel Sliding Plate*		1.5 + 0.8 (Sliding Plate Thickness)
CSHWU	CSHYU	304 Stainless Steel + Ultrahigh molecular weight polyethylene		1.5 + 0.25 (Polyethylene Thickness)

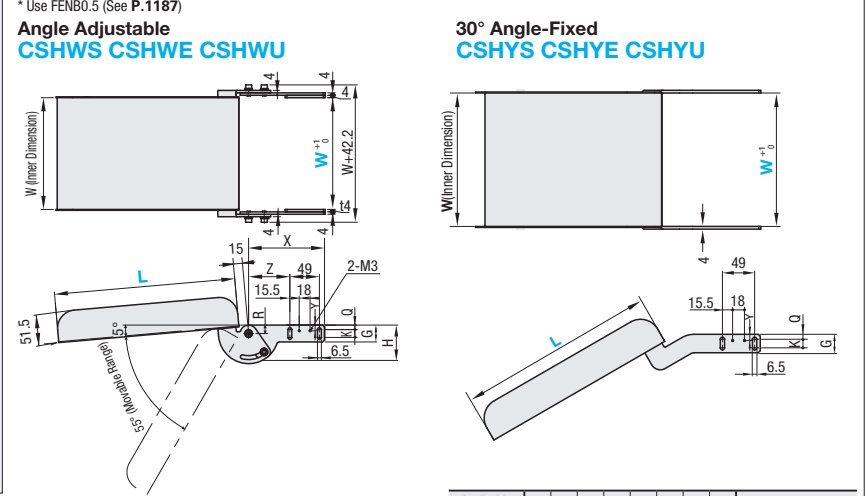

Ⓜ When L ≥ 310, we recommend the alteration YNS (Welding Nut + Leg).
 Ⓜ When mounting to MISUMI conveyors, the W dimensions should be: Belt Width + 40 for Bracket Type A, B; Belt Width + 50 for C.
 Ⓜ We will ship Angle Adjustable Types unassembled. Assembly will be required on your side. The 30° Angle-Fixed Types will be shipped assembled.
 Ⓜ M5/M6 Hex Socket Head Cap Screws and Washers are included for mounting of the conveyor. You will choose either of them and the rest will be left unused.

Angle Adjustable				30° Angle-Fixed			
Part Number	Applicable Conveyor Types	W	L	Part Number	Applicable Conveyor Types	W	L
CSHWS	A	90-540		CSHYS	A	90-540	
CSHWE	B	90-340	70-500	CSHYE	B	90-340	70-500
CSHWU	C	150-550		CSHYU	C	150-550	

Price [Configure Online](#)

W	L	Unit Price				
		CSHWS	CSHWE	CSHWU	CSHYS	CSHYE
90-200	70-100					
	110-200					
	210-300					
	310-400					
201-300	110-200					
	210-300					
	310-400					
	410-500					
301-400	110-200					
	210-300					
	310-400					
	410-500					
401-550	110-200					
	210-300					
	310-400					
	410-500					

Ⓜ W is 150- for the applicable conveyor type C.
 Ordering Example: CSHWE - A - 150 - 300 Days to Ship [Configure Online](#)

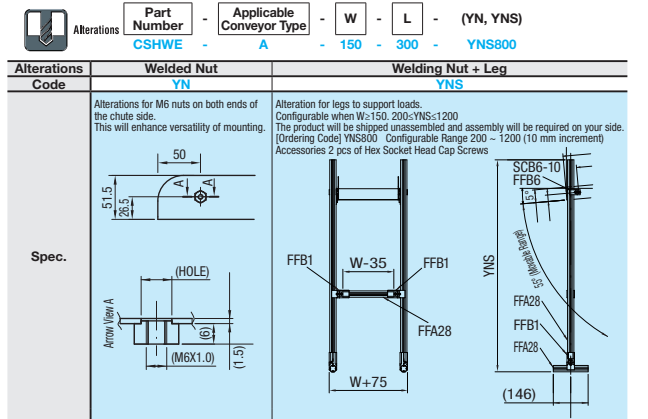
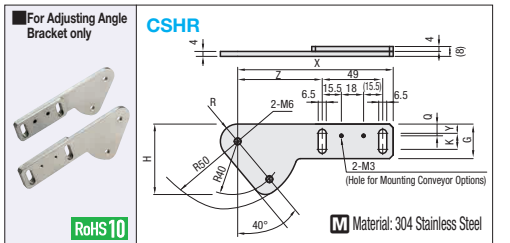

Part Number	Applicable Conveyors	R	Z	X	K	Q	Y	G	H	Unit Price
CSHR	A	SVKN/SVKR/CVGN/CVGP	14	68.5	126	13	9.5	7.5	28	57.1
	B	CVGR/CVWG	14	98.5	156	13	9.5	7.5	28	57.1
	C	CVSY/CV SX	24	83.5	141	30	10	10	48	75



Dust Pans

■Features: The pan receives fallout from the conveyor. Also compatible with liquid including oil.

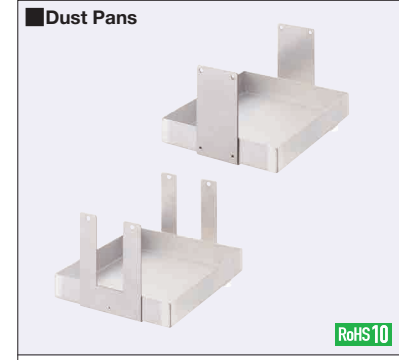

Type	Material	Accessories
CDPT	304 Stainless Steel	Hex Socket Head Cap Screw (304 Stainless Steel) Washer (304 Stainless Steel)

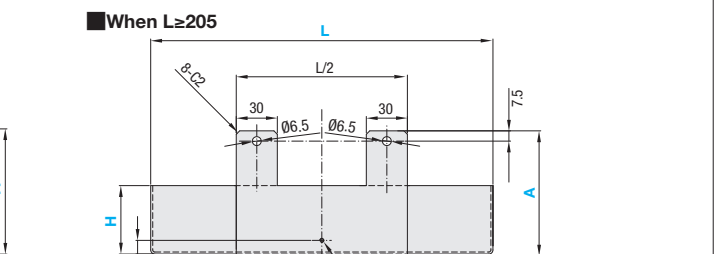
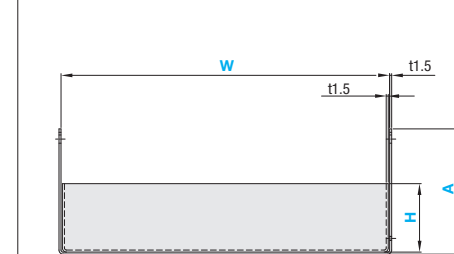

Ⓜ Also compatible with oil or water drops. Ⓜ The pan is screw-mounted and can be separated from the U-shaped bracket.

Part Number	W	L	H	A	Unit Price
	1mm Increment	5mm Increment	10mm Increment	10mm Increment	
CDPT	65-100	100-200 205-300 305-400	20-40	150-200	
	101-200	100-200 205-300 305-400			
	201-300	100-200 205-300 305-400			
	301-400	100-200 205-300 305-400			
	401-550	100-200 205-300 305-400			

[Configure Online](#)

Alterations [Part Number](#) - W - L - H - A - (CLU, CDL, CFN)
 CDPT - 250 - 300 - 20 - 150 - CLU2

Alterations	Water/Oil Discharge Socket Welding	Handle Added	Pan Fixing Knob Added
Code	CLU, CLD, CRU, CRD	CDL	CFN
Spec.			Knurled Knob (M3) to secure the pan is included. Part Number: N00S3-6 Specification: P.2-1078