



For Pricing and Days to Ship, Please Configure Online.

# Welded Mounting Plates / Brackets

Center Symmetrical Type

As opposed to the "Dimension Configurable Type" on the next page, the external dimension tolerance guarantee is ±1.0.

**RoHS 10**

Part Number Type	Material Symbol	Material	Surface Treatment
JSDAS JSAAS JSHDS	SP	Low Carbon Steel	-
	SPU	Steel	Trivalent Chromate (Clear)
	SPK	Steel	Trivalent Chromate (Black)
	AM	5052 Aluminum	-
	AMW	Aluminum Alloy	Anodize (Clear)
AMB	Aluminum Alloy	Anodize (Black)	
SUD	304 Stainless Steel (Passivated 2θ)	-	-

(Common Dimension) ✓

4-C2 or less

Ⓢ 4.5 thickness type is Low Carbon Steel material.

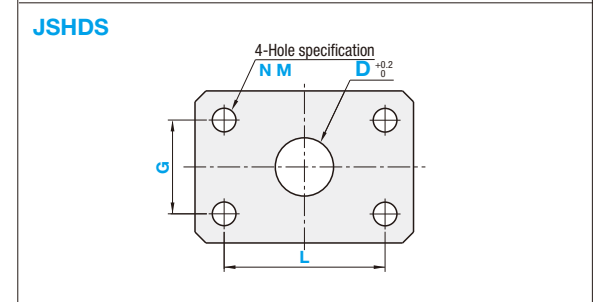
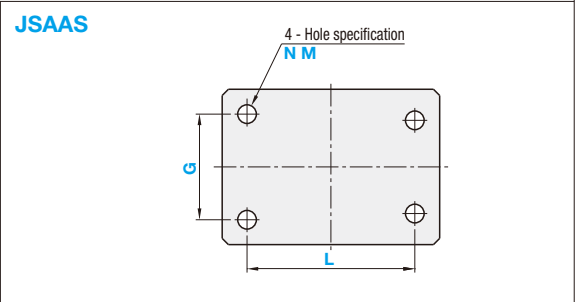
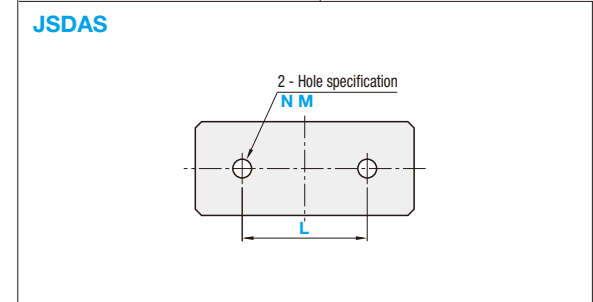

**Hole Type Selection Chart**

Hole Type Code	Bolt Hole N	Tapped Holes M	Through Hole D
Shape Diagram			

Ⓢ For d dimension, see "N Machining Dimensions" on lower section of specification chart.

**Specifications**  
Ⓢ 1. Burr height 0.1 or less

**Machining Limits**  
Ⓢ 2. There are machining limits for thickness between holes, and hole and edge (Ex. b on right Fig.).  
**For machining limits, see P.1720**

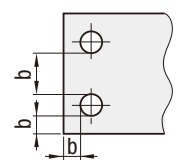

Part Number Type	Material Symbol	Specify 1mm Increment		Selection		L	G	Hole Specification Code / Specify Method	D
		A	B	T	T				
JSDAS JSAAS JSHDS	SP	10   200	10   100	Low Carbon Steel	5052 Aluminum Alloy	Specify 1mm Increment		N (Bolt Hole) Ⓢ 3, 4, 5, 6, 8, 10 (Select)	3~30 (Specify 0.5mm Increment)
	SPU			Steel	304 Stainless Steel				
	SPK			Steel	Steel				
	AM			5052 Aluminum	Aluminum Alloy				
	AMW			Aluminum Alloy	Aluminum Alloy				
AMB	Aluminum Alloy	Aluminum Alloy							
SUD	304 Stainless Steel	304 Stainless Steel	304 Stainless Steel						

Ⓢ N machining dimension

N Specified Value	3	4	5	6	8	10
Through Hole Dia. (d)	3.5	4.5	5.5	6.5	9	11

**Ordering Example**

Part Number: **JSDAS - SP - A80 - B40 - T3.2 - L30 - G - N4**

Part Number: **JSAAS - SPU - A100 - B50 - T2.3 - L90 - G40 - M3**

Part Number: **JSHDS - SUD - A100 - B80 - T2.0 - L80 - G60 - N5 - D30**

Days to Ship **Configure Online**

Price **Configure Online** - Add surface treatment price to example calculated unit price. (Ex.) For JSDAS-SPU-A80-B40-T2.3-L30-N4

**JSDAS Unit Price**

Material Symbol	A	B	T	Unit Price	Volume Discount Rate						
				1-3 pcs.	4-7 pcs.	8-19 pcs.	20-39 pcs.	40-80 pcs.			
SP	10	50	100	2.3							
				3.2							
				4.5							
	51	100	100	2.3							
				3.2							
				4.5							
	101	50	200	2.3							
				3.2							
				4.5							
	51	100	200	2.3							
				3.2							
				4.5							
	AM	10	50	100	2.0						
					3.0						
					4.0						
51		100	100	2.0							
				3.0							
				4.0							
101		50	200	2.0							
				3.0							
				4.0							
51		100	200	2.0							
				3.0							
				4.0							
SUD		10	50	100	2.0						
					3.0						
					4.0						
	51	100	100	2.0							
				3.0							
				4.0							
	101	50	200	2.0							
				3.0							
				4.0							
	51	100	200	2.0							
				3.0							
				4.0							

**JSAAS Unit Price**

Material Symbol	A	B	T	Unit Price	Volume Discount Rate						
				1-3 pcs.	4-7 pcs.	8-19 pcs.	20-39 pcs.	40-80 pcs.			
SP	10	50	100	2.3							
				3.2							
				4.5							
	51	100	100	2.3							
				3.2							
				4.5							
	101	50	200	2.3							
				3.2							
				4.5							
	51	100	200	2.3							
				3.2							
				4.5							
	AM	10	50	100	2.0						
					3.0						
					4.0						
51		100	100	2.0							
				3.0							
				4.0							
101		50	200	2.0							
				3.0							
				4.0							
51		100	200	2.0							
				3.0							
				4.0							
SUD		10	50	100	2.0						
					3.0						
					4.0						
	51	100	100	2.0							
				3.0							
				4.0							
	101	50	200	2.0							
				3.0							
				4.0							
	51	100	200	2.0							
				3.0							
				4.0							

**JSHDS Unit Price**

Material Symbol	A	B	T	Unit Price	Volume Discount Rate						
				1-3 pcs.	4-7 pcs.	8-19 pcs.	20-39 pcs.	40-80 pcs.			
SP	10	50	100	2.3							
				3.2							
				4.5							
	51	100	100	2.3							
				3.2							
				4.5							
	101	50	200	2.3							
				3.2							
				4.5							
	51	100	200	2.3							
				3.2							
				4.5							
	AM	10	50	100	2.0						
					3.0						
					4.0						
51		100	100	2.0							
				3.0							
				4.0							
101		50	200	2.0							
				3.0							
				4.0							
51		100	200	2.0							
				3.0							
				4.0							
SUD		10	50	100	2.0						
					3.0						
					4.0						
	51	100	100	2.0							
				3.0							
				4.0							
	101	50	200	2.0							
				3.0							
				4.0							
	51	100	200	2.0							
				3.0							
				4.0							

**[Surface Treatment Fees]**

Material Symbol	A	B	T	Unit Price	Volume Discount Rate						
				1-3 pcs.	4-7 pcs.	8-19 pcs.	20-39 pcs.	40-80 pcs.			
SPU SPK	10	50	100	2.3							
				3.2							
				4.5							
	51	100	100	2.3							
				3.2							
				4.5							
	101	50	200	2.3							
				3.2							
				4.5							
	51	100	200	2.3							
				3.2							
				4.5							
	AMW AMB	10	50	100	2.0						
					3.0						
					4.0						
51		100	100	2.0							
				3.0							
				4.0							
101		50	200	2.0							
				3.0							
				4.0							
51		100	200	2.0							
				3.0							
				4.0							