



For Pricing and Days to Ship, Please Configure Online.

Spray Nozzles - Circular Spray Pattern / Air Nozzles - De Laval Type



The resin products priced up to 80% lower than the metal products are added to line-up.

Spray Nozzles Circular Spray Pattern

RoHS 10

Type	Material	Max. Operating Pressure	Breakdown Torque	Heat Resistance Temp.
ARDP	Polypropylene (PP)	0.7MPa	15N·m	70°C
ARDA	5052 Aluminum Alloy	1.0MPa	-	200°C
ARDS	303 Stainless Steel	-	-	-

N (Number of Holes) = 6 N (Number of Holes) = 8

Feature: Strong straight air is sprayed through holes on the end.
Applications: For removal of oil, water drops and chips, cooling / drying and air blow to narrow spaces, etc.

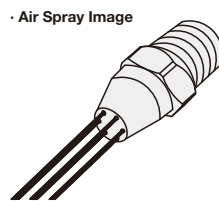
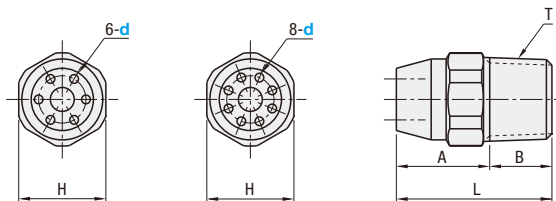

Part Number	Type	d	N (Number of Holes)	Air Flow Rate L/min (for 0.3MPa)	T	L	A	B	H	Mass (g)		
										ARDP	ARDA	ARDS
ARDP	1.0	1.0	6	190	R1/4	25	15	10	14	2	6	15
			8	250							10	28
ARDA	1.4	1.4	6	350	R1/4	25	15	10	14	2	10	28
			8	480							10	28

d	N (Number of Holes)	ARDP		ARDA		ARDS	
		Unit Price	Volume Discount Rate	Unit Price	Volume Discount Rate	Unit Price	Volume Discount Rate
1.0	6						
	8						
1.4	6						
	8						

Air Flow Rate Property Table

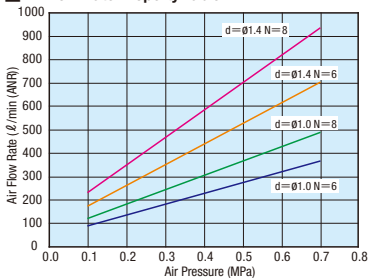

Quietness Property Table

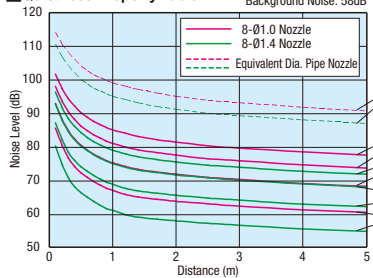

Ordering Example: Part Number ARDA1.0 - N (Number of Holes) 6

Days to Ship: Configure Online

Values on the graph are for reference, not guaranteed.

Air Nozzles De Laval Type

RoHS 10

Type	Material	Max. Operating Pressure	Heat Resistance Temp.
ALVA	5052 Aluminum Alloy	0.7MPa	200°C
ALVS	303 Stainless Steel	0.7MPa	200°C

Feature: Special internal structure enables the air blow at sonic speed, which has powerful colliding force.

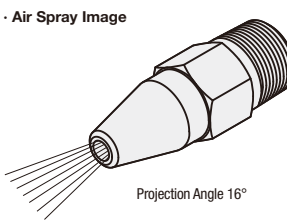
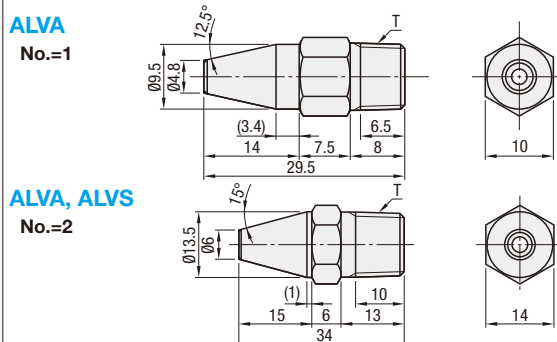

Part Number	Type	No.	T	Orifice	Weight (g)	ALVA		ALVS	
						Unit Price	Volume Discount Rate	Unit Price	Volume Discount Rate
ALVA	1	1	R1/8	0.2.7	8	1-4 pc(s).	5~	1-4 pc(s).	5~
						1-4 pc(s).	5~	1-4 pc(s).	5~
ALVS	2	2	R1/4	0.3.8	11				

Air Flow Rate Property Table

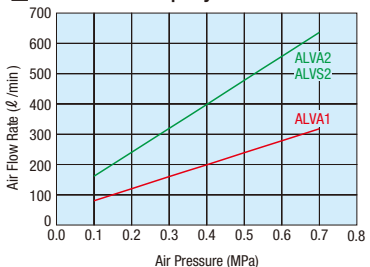

Quietness Property Table

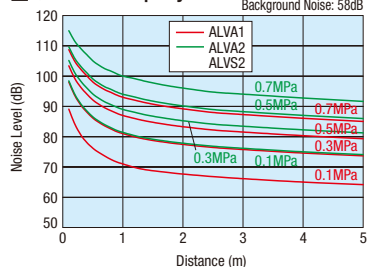

Velocity Decay Graph (Ref.)

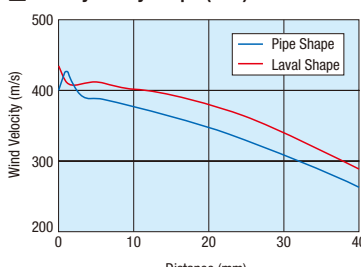

Ordering Example: Part Number ALVA1

Days to Ship: Configure Online

Air Nozzles - Economy Type / Point Nozzles

Air Nozzles Economy Type

RoHS 10



NZAK (Narrow Injection Port Type)

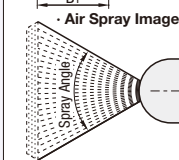
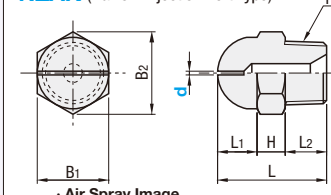

Feature: Gas spreads fan-like in line to the slit.
Applications: Steam Humidification, Drying, Air Blow, etc.

NZAL (Wide Injection Port Type)

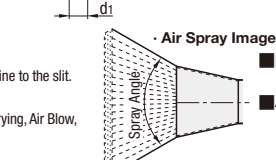
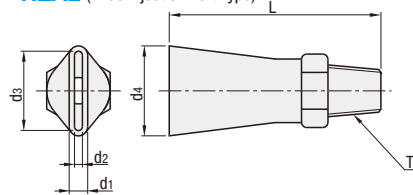

Feature: Air sprayed at wide angle.
Applications: Dust Proof, Air Blow, etc.

Material: 304 Stainless Steel

Part Number	Type	No.	d	Slot Width	T	L	L1	L2	H	B1	B2	Mass (g)	Unit Price	Volume Discount Rate
NZAK	1	1	0.6	0.8	R1/8	22	8	8	6	12	13.8	12		
													1.0	
													1.2	
													1.6	
NZAK	2	1	1.4	1.6	R1/4	25	8.5	10	6.5	14	16	20		

Part Number	Type	No.	L	d1	d2	d3	d4	T	Mass (g)	Unit Price	Volume Discount Rate
NZAL	11	40	3.1	1.5	10	11.6	15	R1/8	15		
										22	
										33	

Projection Angle

Pressure [MPa]	Projection Angle										NZAL		
	1-0.6	1-0.8	1-1.0	1-1.2	1-1.6	2-0.6	2-0.8	2-1.0	2-1.2	2-1.6	11	22	33
0.1	55°	60°	65°	65°	70°	60°	60°	65°	65°	70°	25°	50°	55°
0.2	60°	65°	70°	70°	70°	65°	70°	75°	70°	70°			
0.3	65°	70°	75°	75°	75°	70°	75°	80°	75°	75°			
0.4	70°	75°	80°	80°	80°	75°	80°	85°	80°	80°			
0.5	75°	80°	80°	80°	85°	80°	85°	85°	85°	85°			
0.6	80°	80°	85°	85°	85°	85°	85°	85°	85°	85°			

Listed values are for reference, not guaranteed.

Ordering Example: Part Number NZAK2 - d 1.0

Days to Ship: Configure Online

Air Flow Rate Property Table

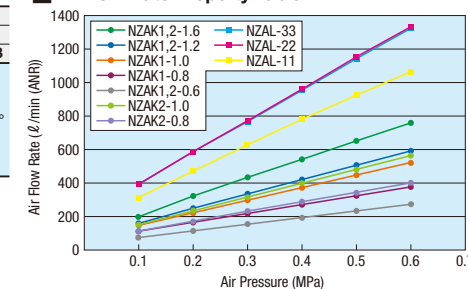

Values on the graph are for reference, not guaranteed.

Point Nozzles

RoHS 10

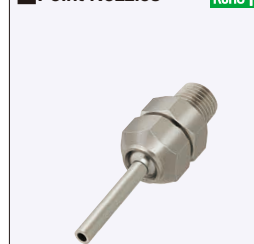

PNZRF

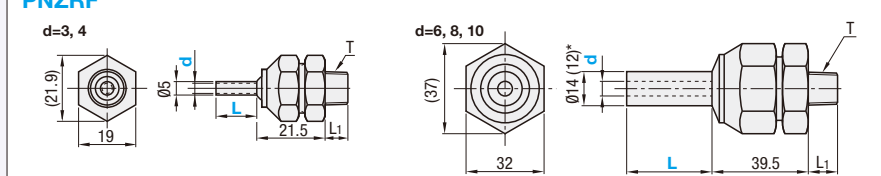

Angle Specification Range Tighten the hex nut and fix the nozzle at a desired angle.

*Dimension () is for d=6.

Material: 304 Stainless Steel

Part Number	Type	No.	d	L	T	L1	Unit Price 1~19 pc(s).											
							L10, 15	L30	L50	L75	L100							
PNZRF	1	1	3	10	M5	8												
				15														
				30														
				50														
				2			2	3	10	R1/8	10							
									15									
	30																	
	50																	
	8	12	75															
			100															

For orders larger than indicated quantity, please request a quotation.

Ordering Example: Part Number PNZRF2 - d 3 - L 10

Days to Ship: Configure Online