

Sanitary Pipe Fittings

Both Ends Weld-On

Sanitary Pipe Fittings / Sanitary Adapter Fittings

Weld-On Threaded

Both Ends Weld-On, Elbow



RoHS10

Type	Material
SNWE	304 Stainless Steel
SNWES	316L Stainless Steel

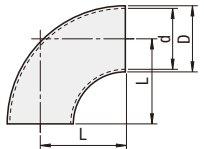

Both Ends Weld-On, 45° Elbow



RoHS10

Type	Material
SNWHE	304 Stainless Steel
SNWHES	316L Stainless Steel

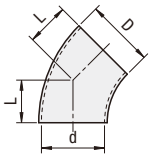

Both Ends Weld-On, Tees



RoHS10

Type	Material
SNWT	304 Stainless Steel
SNWTS	316L Stainless Steel

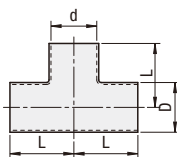

Both Ends Weld-On, Reducing Tees



RoHS10

Type	Material
SNWTD	304 Stainless Steel

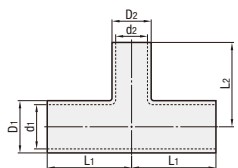

Blind Nut



RoHS10

Type	Material
SNYBN	304 Stainless Steel

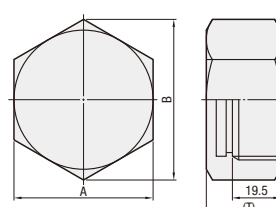

Part Number		D	d	L	SNWE		SNWES	
Type	No.				Unit Price	Volume Discount Rate	Unit Price	Volume Discount Rate
SNWES	8A	13.8	10.5	38	-	-	-	-
	10A	17.3	14.0		-	-	-	-
	15A	21.7	17.5		-	-	-	-
SNWE	1S	25.4	23	34	-	-	-	-
	1.5S	38.1	35.7	49	-	-	-	-
	2S	50.8	47.8	61	-	-	-	-
	2.5S	63.5	59.5	84	-	-	-	-
	3S	76.3	72.3	89	-	-	-	-

Part Number		D	d	L	SNWHE		SNWHES	
Type	No.				Unit Price	Volume Discount Rate	Unit Price	Volume Discount Rate
SNWHE	1S	25.4	23	15.8	-	-	-	-
	1.5S	38.1	35.7	23.7	-	-	-	-
	2S	50.8	47.8	31.6	-	-	-	-
	2.5S	63.5	59.5	42	-	-	-	-
	3S	76.3	72.3	52.6	-	-	-	-

Part Number		D	d	L	SNWT		SNWTS	
Type	No.				Unit Price	Volume Discount Rate	Unit Price	Volume Discount Rate
SNWT	1S	25.4	23.0	34.0	-	-	-	-
	1.5S	38.1	35.7	49.0	-	-	-	-
	2S	50.8	47.8	61.0	-	-	-	-
	2.5S	63.5	59.5	84.0	-	-	-	-
	3S	76.3	72.3	89.0	-	-	-	-

Part Number		D1	d1	D2	d2	L1	L2	Unit Price
Type	No.							Qty. 1-9
SNWTD	1.5S-1S	38.1	35.7	25.4	23.0	49	45	-
	2S-1S	50.8	47.8	25.4	23.0	61	51	-
	2S-1.5S	50.8	47.8	38.1	35.7	61	64	-
	2.5S-1.5S	63.5	59.5	38.1	35.7	84	70	-
	2.5S-2S	63.5	59.5	50.8	47.8	84	82	-

Part Number		A	B	(T)	Unit Price	Volume Discount Rate
Type	No.				Qty. 1-4	5-9
SNYBN	1S	46.0	53.1	30.0	-	-
	1.5S	56.0	64.6		-	-
	2S	71.0	81.9		-	-
	2.5S	85.0	98.1		-	-
	3S	100.0	115.4		-	-

Ordering Example Part Number SNWE2S Days to Ship [Configure Online](#) Example

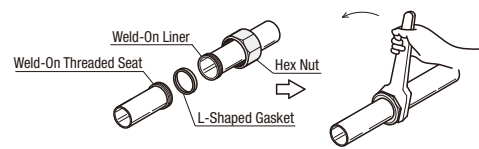

Weld-On Threaded Seats



RoHS10

Type	Material
SNYNS	304 Stainless Steel

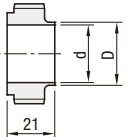

Weld-On Liners



RoHS10

Type	Material
SNYRN	304 Stainless Steel

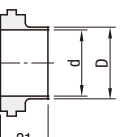

Hex Nut



RoHS10

Type	Material
SNRN	304 Stainless Steel

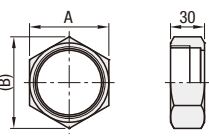

L-Shaped Gaskets



RoHS10

Type	Material
SNLGS	Silicone
SNLGSF	PTFE

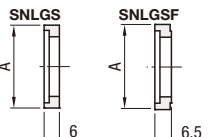

Threaded Type



RoHS10

Type	Material
SNWZFA	316L Stainless Steel

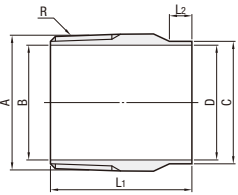

Hose



RoHS10

Type	Material
SNWHAD	304 Stainless Steel

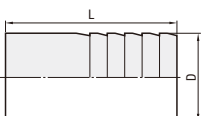

Ordering Example Part Number SNWTD2S-1.5S SNWZFA1S Days to Ship [Configure Online](#)

Part Number		D	d	Unit Price	Volume Discount Rate
Type	No.			Qty. 1-9	10-19
SNYNS	1S	25.4	23.0	-	-
	1.5S	38.1	35.7	-	-
	2S	50.8	47.8	-	-
	2.5S	63.5	59.5	-	-
	3S	76.3	72.3	-	-

Part Number		D	d	Unit Price	Volume Discount Rate
Type	No.			Qty. 1-9	10-19
SNYRN	1S	25.4	23.0	-	-
	1.5S	38.1	35.7	-	-
	2S	50.8	47.8	-	-
	2.5S	63.5	59.5	-	-
	3S	76.3	72.3	-	-

Part Number		A	(B)	Unit Price	Volume Discount Rate
Type	No.			Qty. 1-9	10-19
SNRN	1S	46	53.1	-	-
	1.5S	56	64.6	-	-
	2S	71	81.9	-	-
	2.5S	85	98.1	-	-
	3S	100	115.4	-	-

Part Number		A		SNLGS		SNLGSF		Unit Price	Volume Discount Rate
Type	No.	SNLGS	SNLGSF	Qty. 1-19	20-49	Qty. 1-19	20-49	Qty. 1-19	20-49
SNLGS	1S	32.5	33.4	-	-	-	-	-	-
	1.5S	46.0	46.8	-	-	-	-	-	-
	2S	59.5	60.5	-	-	-	-	-	-
	2.5S	73.2	74.0	-	-	-	-	-	-
	3S	86.5	87.0	-	-	-	-	-	-

Use Weld-On Threaded Seats (SNYNS) with gaskets. Ordering Example Part Number SNYNS1S Days to Ship [Configure Online](#)

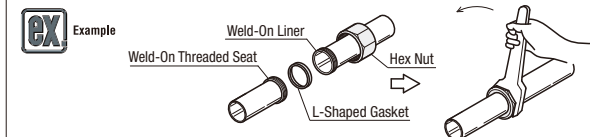

Part Number		Nominal	R (PT)	A	B	C	D	L1	L2	Unit Price	Volume Discount Rate
Type	No.									Qty. 1-4	5-9
SNWZFA	1S	4	1/2	21.7	15.7	25.4	23	39	7	-	-
		6	3/4	27.2	21	25.4	23	39	7	-	-
		8	1	34	26	25.4	23	39	7	-	-
	1.5S	8	1	34	26	38.1	35.7	39	7	-	-
		10	1 1/4	42.7	35.7	38.1	35.7	44	7	-	-
		12	1 1/2	48.6	40	50.8	47.8	49	-	-	-

For orders larger than indicated quantity, please request a quotation.

Part Number		D	L	Unit Price	Volume Discount Rate
Type	No.			Qty. 1-9	10-14
SNWHAD	1S	25.4	60	-	-
	1.5S	38.1	80	-	-
	2S	50.8	80	-	-
	2.5S	63.5	80	-	-
	3S	76.3	80	-	-

For orders larger than indicated quantity, please request a quotation.