

Screw-In Casters

Light / Medium Load

Spec.Change

Printed in Purple

Load Rating
300~
1200N

Screw-In Mount

Screw-In Casters / Side Mount Brackets for Casters / Dedicated Wrenches for Screw-In Casters

Low Profile

Load Rating
1000~
1600N

Screw-In Mount



Swivel HSGN

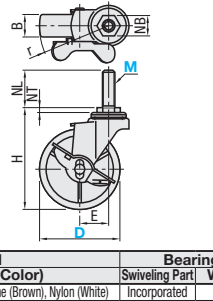

Swivel+Brake HSGNS

Type	Part Number	D	M (Coarse)	Wheel Material	Wheel Width B			H	E	NB	NT	NL	r	Allowable Load (N)			Mass (g)			Unit Price			
					R	U	N							R	U	N	R	U	N	R	U	N	
Swivel Screw-In Type	HSGN	50	8	R (Rubber)	18	20	21	21	22	14	14	14	47	300	380	400	195	175	165				
		65	12		21	21	21	23	19	4.8	35	56	270	220	210								
		75	12		21	21	21	27			65	400	450	500	310	240	225						
		100	12		25	28	25	31	4	4	82	500	600	600	585	435	405						
Swivel Screw-In Stopper Type	HSGNS	50	8	U (Urethane)	18	20	21	21	22	14	14	49	300	380	400	220	200	190					
		65	12		21	21	21	23	19	4.8	35	57	300	400		250	235						
		75	12		21	21	21	27			65	400	450	500	340	275	250						
		100	12		25	28	25	31	4	4	82	500	600	600	650	620	585						

Ordering Example: Part Number **HSGN75** - **M** - Wheel Material **12** - Days to Ship **U**

[Configure Online](#) [Price Configure Online](#)

*The color of Urethane used as a wheel material had been changed from brown to gray in April of 2012, along with a width of a wheel (described as B in the following larger table).



Swivel CMGN

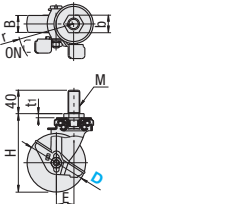

Swivel+Brake CMGNS

Type	Part Number	D	Wheel Material	Wheel Width B			H	M (Coarse)	b	t ₁	E	r	Allowable Load (N)			Mass (g)			Unit Price		
				R	U	N							R	U	N	R	U	N	R	U	N
Screw-In Type	CMGN	75	R (Rubber)	25	-	25	97	16	23	4	25	63	600	-	800	476	-	390			
		100		32	30	29	134	20	30	7	30	80	1200	1200	1200	1026	1474	1000			
Swivel Screw-In with Stopper	CMGNS	75	U (Urethane)*1	25	-	25	97	16	23	4	25	72	600	-	800	523	-	445			
		100		32	30	29	134	20	30	7	30	98	1200	1200	1200	1133	1690	1100			

Ordering Example: Part Number **CMGN75** - Wheel Material **R**

[Configure Online](#) [Price Configure Online](#)

*1: Urethane wheels are available for D100 only.



Swivel CSJTN

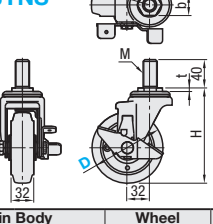

Swivel+Brake CSJTNS

Type	Part Number	D	Wheel Material	H	M (Coarse)	b	t	r	Allowable Load (N)	Mass (g)	Unit Price
100B	810										
125A	1025										
125B	950										
Swivel Screw-In Brake Type	CSJTNS	100A	R (Rubber)	134	16	23	4.7	86	1200	965	
		100B								840	
		125A								1115	
		125B								1040	

Ordering Example: Part Number **CSJTN100B** - Wheel Material **R**

[Configure Online](#) [Price Configure Online](#)

Feature: Low installation height with low gravity center that allows users to use them for conveying heavy objects.



Swivel CHJFN



Swivel+Brake CHJNSM

Type	Part Number	D	M (Coarse)	H	B	b	t	E	r	Allowable Load (N)		Mass (g)	Unit Price	
										Plastic	MC Nylon		CHJFN / CHJFNS (Plastic)	CHJNM / CHJNSM (MC Nylon)
Swivel + Screw-In	CHJFN (Plastic) CHJNM (MC Nylon)	*50A	40	16	74	28	23	7.9	25	51	1000	1000	390	
		*50B		20									430	
		65A		16	93								620	
		65B		20	107	38	30	5.8	22	61	1600	1600	760	
		75A		20									790	
Swivel + Screw-In with Stopper	CHJFNS (Plastic) CHJNSM (MC Nylon)	*50A	80	16	74	28	23	7.9	25	65	1000	1000	430	
		*50B		20									470	
		65A		16	93								680	
		65B		20	107	38	30	5.8	22	67	1500	1500	710	
		75A		20									830	
		75B	20								860			

Ordering Example: Part Number **CHJNM65A** - ℓ **40**

[Configure Online](#) [Price Configure Online](#)

*D50A and D50B have no bearings in a wheel.

Side Mount Brackets for Casters



CPHM

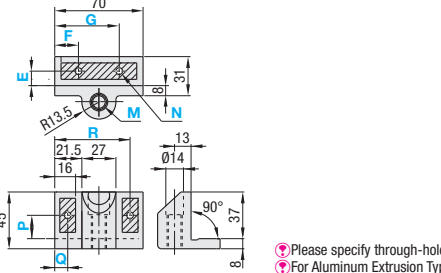

Hole Type: Through Hole

Code: N

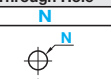
Shape: 

Machining Specification:

Dimension	N	5	6
Nominal Dia.	d	6	7

Material: Aluminum Casting Alloy 383.0
Surface Treatment: Baked Paint (Silver)

Please specify through-hole locations within .
For Aluminum Extrusion Type, see P750.

Part Number	N	Drilling Position 0.5mm Increment						Mass (g)	Unit Price		
		M (Coarse)	(Through Hole)	E	F	G	P			Q	R
CPHM	10	5	6	8~15	8~28	42~62	8~29	7~13	57~63	135	

Ordering Example: Part Number **CPHM10** - N **5** - E **E12** - F **F25.5** - G **G46.5** - P **P28** - Q **Q13** - R **R58**

[Configure Online](#) [Price Configure Online](#)



Dedicated Wrenches for Screw-In Casters

PFSP

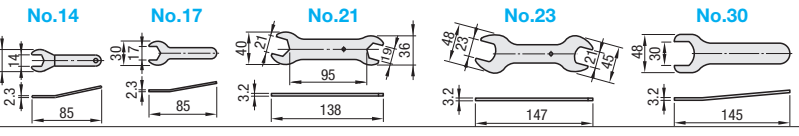

Part Number	Mass (g)	Unit Price
14	18	
17	27	
21	58	
23	61	
30	73	

Ordering Example: Part Number **PFSP14**

[Configure Online](#) [Price Configure Online](#)