

Casters

Light / Medium Load

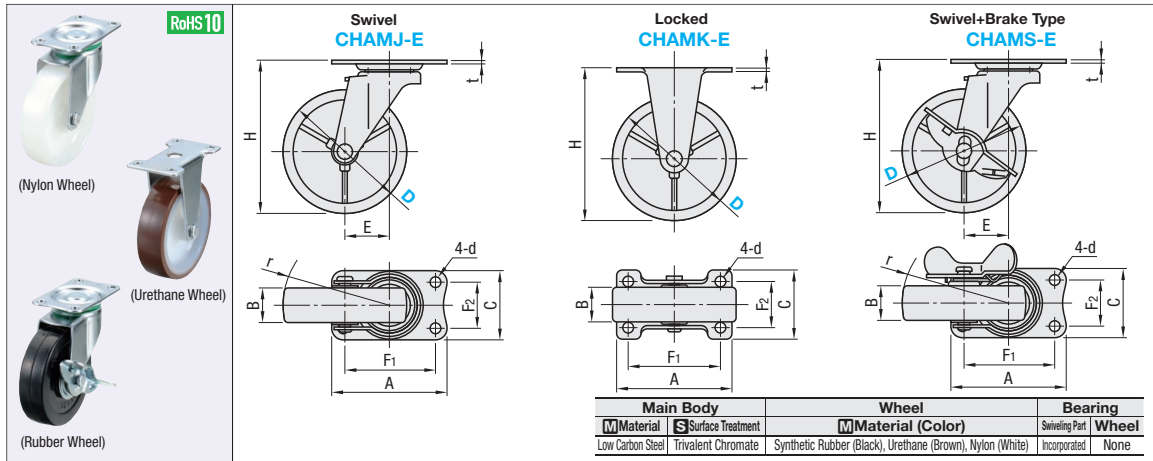

Type	Part Number	Wheel Material	H	A	C	F1	F2	d	E	r	B				Allowable Load (N)				Mass (g)			Unit Price		
											R	U	N	t	R	U	N	R	U	N	R	U	N	
Swivel Type	CHAMJ-E	R (Rubber)	50	65	70	42	56	28	6.5	22	47	20	21	21	2	300	380	400	180	165	150			
			65	82	70	42	56	28	6.5	27	65	21	21	2	400	450	500	250	200	190				
			75	92	100	58	82	40	8.8	31	82	25	28	25	2.3	500	600	600	600	465	420			
			100	122	100	58	82	40	8.8	31	82	25	28	25	2.3	500	600	600	600	465	420			
Fixed Type	CHAMK-E	U (Urethane)	50	65	70	42	56	28	6.5	-	-	21	21	2	300	380	400	195	145	135				
			65	82	70	42	56	28	6.5	-	-	21	21	2	400	450	500	230	160	145				
			75	92	100	58	82	40	8.8	-	-	25	28	25	2.3	500	600	600	505	345	325			
			100	122	100	58	82	40	8.8	-	-	25	28	25	2.3	500	600	600	505	345	325			
Swivel with Stopper Type	CHAMS-E	N (Nylon)	50	65	70	42	56	28	6.5	22	47	20	21	2	300	380	400	205	185	170				
			65	82	70	42	56	28	6.5	23	56	21	21	2	400	450	500	285	215	215				
			75	92	100	58	82	40	8.8	27	65	21	21	2	400	450	500	320	250	230				
			100	122	100	58	82	40	8.8	27	65	21	21	2	400	450	500	320	250	230				

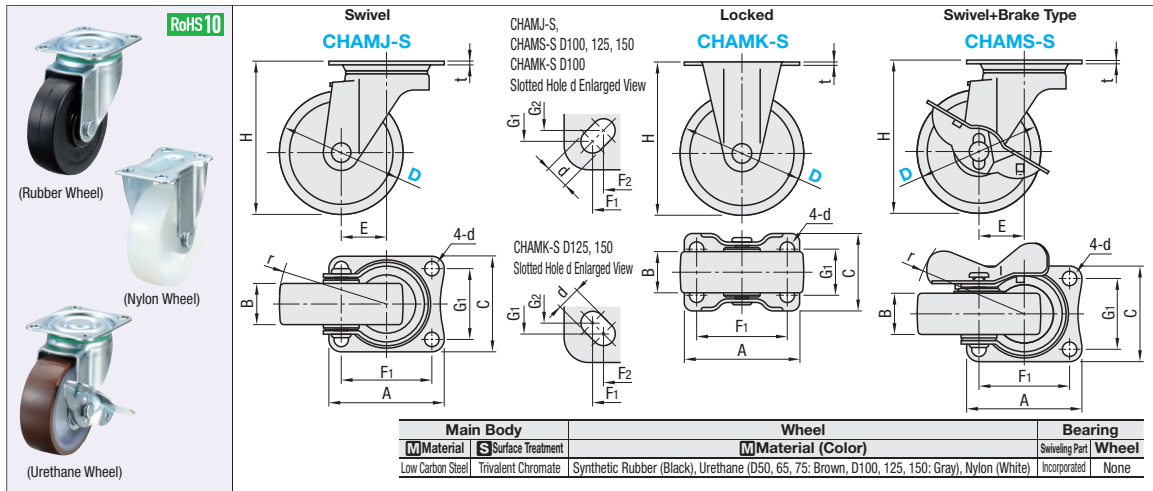

Type	Part Number	Wheel Material	H	A	C	F1	F2	G1	G2	d	E	r	B				Allowable Load (N)				Mass (g)			Unit Price		
													R	U	N	t	R	U	N	R	U	N	R	U	N	
Swivel Type	CHAMJ-S	R (Rubber)	50	70	58	55	-	42	-	8.8	27	53	28	25	28	2.3	500	600	600	325	305	290				
			65	85	70	58	55	-	42	-	8.8	27	61	25	26	2.3	600	700	700	375	325	310				
			75	93	100	90	71	68	71	68	11	32	83	32	32	3.2	1200	1000	1200	920	790	770				
			125	168	102	102	80	75	80	75	11	40	105	38	40	4.0	1500	1300	1500	1505	1465	1315				
			150	190	102	102	80	75	80	75	11	40	115	40	4.0	1600	1400	1600	1710	1585	1490					
Fixed Type	CHAMK-S	U (Urethane)	50	70	47	55	-	28	-	8.8	-	-	-	28	2.3	500	600	600	195	175	160					
			65	85	70	47	55	-	28	-	8.8	-	-	25	2.3	600	700	700	250	200	185					
			75	93	100	90	75	90	80	50	45	11	32	32	32	3.2	1200	1000	1200	740	610	585				
			125	168	136	100	100	100	100	100	100	11	38	38	38	4.0	1500	1300	1500	1135	1090	945				
			150	190	137	93	112	100	56	53	11	40	40	40	4.0	1600	1400	1600	1290	1160	1100					
Swivel with Brake Type	CHAMS-S	N (Nylon)	50	70	58	55	-	42	-	8.8	27	67	28	25	28	2.3	500	600	600	345	335	310				
			65	85	70	58	55	-	42	-	8.8	27	68	25	25	2.3	600	700	700	430	375	350				
			75	93	100	90	71	68	71	68	11	32	86	32	32	3.2	1200	1000	1200	1005	875	850				
			125	168	102	102	80	75	80	75	11	40	108	38	40	4.0	1500	1300	1500	1690	1650	1505				
			150	190	102	102	80	75	80	75	11	40	115	40	4.0	1600	1400	1600	1875	1750	1700					

Casters/Conductive (Static Control) / Stainless Steel

Stainless Steel Type

*Electrically conductive rubber specific volume resistivity: between 10⁴ to 10⁶Ω·cm

Type	Part Number		D	B	H	A	C	r		K		F	d	t	E	G	Allowable Load (N)	Mass (g)	Unit Price	
	Steel Type	Stainless Steel Type						Steel Type	Stainless Steel Type	Steel Type	Stainless Steel Type									
Swivel Type	CRJJDG	CSRJJDG	50	20	65	42	47	47	-	-	56	6.5	2	22	28	300	190			
			65	25	85	70	61	61	-	-	55	8.8	2.3	27	42	500	370			
			75	25	93	58	66	66	-	-	82	8.8	2.3	28	40	600	420			
			100	122	100	58	82	82	-	-	82	8.8	2.3	31	40	500	600			
Fixed Type	CRKDG	CSRKDG	50	20	65	42	-	-	-	-	56	6.5	2	-	28	300	140			
			65	25	85	47	-	-	-	-	55	8.8	2.3	-	28	500	250			
			75	25	93	58	-	-	-	-	82	8.8	2.3	-	40	600	290			
			100	122	100	58	-	-	-	-	82	8.8	2.3	-	40	500	510			
Brake Type	CRSDG	CSRSDG	50	20	65	42	51	51	32	31	56	6.5	2	22	28	300	210			
			65	25	85	58	67	67	43	40	55	8.8	2.3	27	42	500	430			
			75	25	93	58	68	68	43	40	55	8.8	2.3	28	42	600	470			
			100	122	100	58	82	82	44	43	82	8.8	2.3	31	40	500	670			

Type	Part Number	Wheel Material	B				H	A	C	F1	F2	d	t	E	G1	G2	K	r	Allowable Load (N)				Mass (g)	Unit Price		
			R	U	N	t													R	U	N	R		U	N	
Swivel Type	CSMJU	R (Rubber)*1	75	25	26	25	93	70	58	55	-	8.8	2.3	28	42	-	66	600	700	800	390					
			100	29	32	32	132	90	90	71	68	11	3	32	71	68	82	800	1000	1000	950					
			125	32	32	32	168	102	102	80	75	11	3	36	80	75	99	1000	1200	-	1230					
			150	40	40	40	190	102	102	80	75	11	3	40	80	75	115	-	1800	1600	1500	-				
			150	40	40	40	190	102	102	80	75	11	3	40	80	75	115	-	1800	1600	1290	-				
Fixed Type	CSMKU	U (Urethane)	75	25	26	25	93	70	47	55	-	8.8	2.3	28	-	-	600	700	800	270						
			100	29	32	32	132	110	75	90	80	11	3	50	45	-	800	1000	1000	720						
			125	32	32	32	168	140	94	112	100	11	3	53	56	-	1000	1200	-	1180						
			150	40	40	40	190	102	102	80	75	11	3	80	75	-	1800	1600	1290	-						
			150	40	40	40	190	102	102	80	75	11	3	80	75	-	1800	1600	1720	-						
Brake Type	CSMSPU	N (Nylon)*2	75	25	26	25	93	70	58	55	-	8.8	2.3	28	42	-	68	600	700	800	430					
			100	29	32	32	132	90	90	71	68	11	3	32	71	68	55	86	800	1000	1060					
			125	32	32	32	168	102	102	80	75	11	3	34	80	75	54	97	1000	1200	-	1340				
			150	40	40	40	190	102	102	80	75	11	3	40	80	75	65	115	-	1800	1600	1720	-			
			150	40	40	40	190	102	102	80	75	11	3	40	80	75	65	115	-	1800	1600	1720	-			

*1 R(Rubber) Type of D dimension 150 is not available for Swivel, Fixed and Stopper Types. *2 N(Nylon) Type of D dimension 125 is not available for Swivel, Fixed and Stopper Type.

Ordering Example: Part Number - Wheel Material
CRJJDG100 - R
CSMKU125 - U

Days to Ship: Configure Online

Price: Configure Online

Ordering Example: Part Number - Wheel Material
CHAMS-E75 - U
CHAMJ-S65 - R

Days to Ship: Configure Online

Price: Configure Online