

Panel Brackets - Panel Mounting Screws

Steel / Stainless Steel

Panel Brackets Steel / Stainless Steel

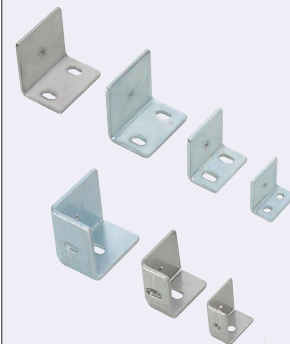

Type	Material	Surface Treatment
Steel Type	Low Carbon Steel	Bright Chromate Plating
Stainless Steel Type	304 Stainless Steel	-

For Middle Mounting

Steel Type **HCBV5**
Stainless Steel Type **SHCBV5**

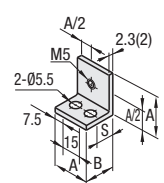

Steel Type **HCBV6**
HCBV8
HCBV8-45
Stainless Steel Type **SHCBV6**
SHCBV8
SHCBV8-45

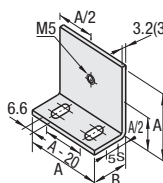

For Corner Mounting

Steel Type **HCBCV5**
Stainless Steel Type **SHCBCV5**

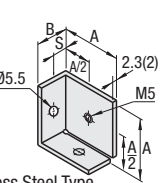

Steel Type **HCBCV6**
HCBCV8
HCBCV8-45
Stainless Steel Type **SHCBCV6**
SHCBCV8
SHCBCV8-45

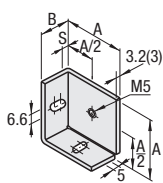

The values in () are for Stainless Steel Type.
So as to enhance reinforcement, the plate attachment hole height A/2 differs from that of Aluminum Type and Plastic Type.



Two methods of panel mounting are available for No. 6, 8 and 8-45 of Steel Type and Stainless Type (5mm thick or less) since these products have slotted holes.

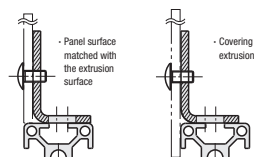

Steel Type

Part Number	Mass	Difference between the Extrusion Side and Attachment Face	S	B	Screw / Nut		HCBV			SHCBV		
					Screw	Nut	Unit Price	Volume Discount Rate	Unit Price	Volume Discount Rate	Unit Price	Volume Discount Rate
HCBV5	29	23	5	10	30	18	CBM5-8	HNTT5-5				
HCBV6	79	60	0-5	40	40	25	CBM6-12	HNTT6-6	2			
HCBV8	124	94	(Variable)	15	50	35	CBM6-15	HNTT8-6				
8-45				17.5	50	35	CBM6-15	HNTT8-6				

Stainless Steel Type

Part Number	Mass	Difference between the Extrusion Side and Attachment Face	S	B	Screw / Nut		SHCBV			SHCBCV		
					Screw	Nut	Unit Price	Volume Discount Rate	Unit Price	Volume Discount Rate	Unit Price	Volume Discount Rate
SHCBV5	23	18.5	5	10	30	18	SCB5-8	HNTT5N5-5				
SHCBV6	62.5	50	0-5	40	40	25	SCB6-12	HNTT6N6-6	2			
SHCBV8	113	85.5	(Variable)	15	50	35	SCB6-15	HNTT8N8-6				
8-45				17.5	50	35	SCB6-15	HNTT8N8-6				

Ordering Example: Part Number **HCBV6** - (SET) **SHCBCV5**

Days to Ship **Configure Online**

Alteration	Code	Spec.	Bracket	Screw / Nut				Price Adder
				For Extrusion Fitting		For Panel Fitting		
				Screw	Nut	Screw	Nut	
Applicable Screw and Nut Set	SET	Applicable screws and nuts come in a set. When SET is specified, the product is not RoHS compliant.	HCBV5	CBM5-8	HNTT5-5			
			HCBV6	CBM6-12	HNTT6-6			
			HCBV8	CBM6-15	HNTT8-6			
			HCBV8-45	CBM6-15	HNTT8-6			
			SHCBCV5	SCB5-6	HNTT5N5-5	2		
			SHCBCV6	SCB6-10	HNTT6N6-6			
			SHCBCV8	SCB6-10	HNTT6N6-6			
			SHCBCV8-45	SCB6-15	HNTT8N8-6			
			SHCBCV8	SCB6-15	HNTT8N8-6			
			SHCBCV8-45	SCB6-15	HNTT8N8-6			
SHCBCV8-45	SCB6-15	HNTT8N8-6						

Panel Mounting Screws

HCBM
SHCBM (Stainless Steel)
HCBMB (Trivalent Chromate)

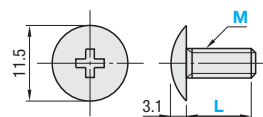

Type	Material	Surface Treatment
HCBM	Carbon Steel for Mechanical Structure	Bright Chromate Plating
SHCBM	304 Stainless Steel	-
HCBMB	Carbon Steel for Mechanical Structure	Trivalent Chromate (Black)

Part Number	Length	HCBM		SHCBM		HCBMB	
		Unit Price	Volume Discount Rate	Unit Price	Volume Discount Rate	Unit Price	Volume Discount Rate
HCBM	10						
SHCBM	12						
HCBMB	15						

L dimension 15 is for HCBM. For other screws, see P675.

M-L	HCBM	SHCBM	HCBMB
5-10	Set of 500 pcs. (SET1)	Set of 500 pcs. (SET1)	Set of 500 pcs. (SET1)
5-12			
5-15			

When ordering please note the quantity. 500 will be delivered for HCBM5-10-SET1 order.

Ordering Example: Part Number **HCBM5** - **L**
SHCBCV5 - **10**
Part Number **L** - **SET1**
HCBM5 - **10** - **SET1** (500 pcs.)

Slide Rails / Slide Spacers

Resin

Slide Rails



HRLFLJ2

(For 2 Rows of 5mm Thick Plate)

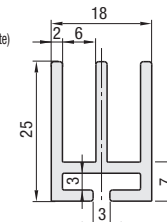

HRLFLJ3

(For 3 Rows of 5mm Thick Plate)

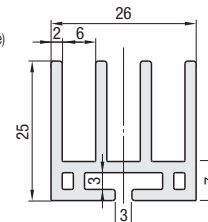

Use the Slide Rail Connectors to connect the Slide Rail to Aluminum Extrusions. Material: ABS Resin Resin (Light Gray)

Part Number	Length 1mm Increment	Extrusion (Series)	Mass kg/m	Unit Price/m
HRLFLJ	2	HFS5	0.185	
	3	HFS6	0.277	
		HFS8(-45)		

Slide Rail Connectors



HRLCN5

(For 2 Rows of 5mm Thick Plate)

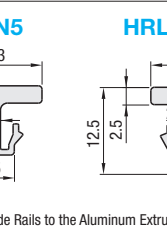

HRLCN6

(For 3 Rows of 5mm Thick Plate)

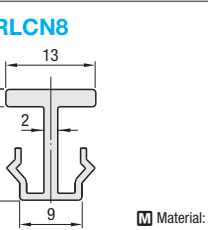

Used to connect the Slide Rails to the Aluminum Extrusions. Material: Polypropylene (Light Gray)

Part Number	Length 1mm Increment	Extrusion (Series)	Mass kg/m	Unit Price/m
HRLCN	5	HFS5	0.045	
	6	HFS6	0.064	
	8	HFS8(-45)	0.072	

Ordering Example: Part Number **HRLFLJ3** - Length **1000**
HRLCN6 - Length **1000**
Days to Ship **Configure Online** Price **Configure Online**



Connection with Extrusion

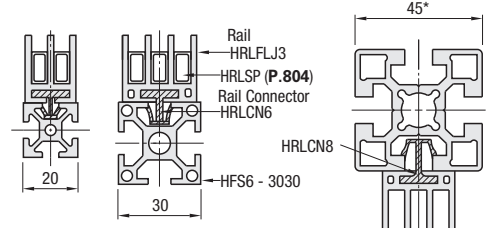

*Also use HRLCN8 for HFS8-50 and HFS8-60.

Select HRLFLJ3 and HRLCN6 in order to attach 3-rows rail to the frames of HFS6 series.

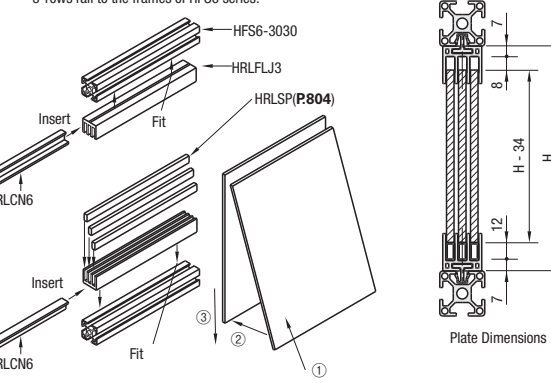

Plate Dimensions

Slide Spacers



HRLSP

(For 2 Rows of 5mm Thick Plate)

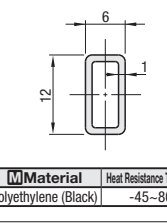

Example

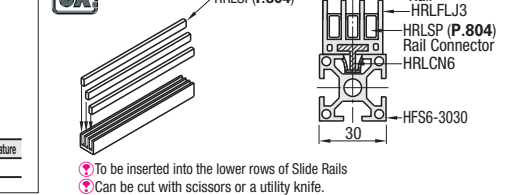

To be inserted into the lower rows of Slide Rails. Can be cut with scissors or a utility knife.

Part Number	Length mm	Unit Price	Volume Discount Rate	Part Number	Length mm	Unit Price (Set of 30 pcs.)
HRLSP	2000	1-9 pc(s)	10-49	HRLSP-SET	2000	
				(Set of 30 pcs.)		

Ordering Example: Part Number **HRLSP** - Length **2000**
HRLSP-SET - Length **2000**
Days to Ship **Configure Online**