

## Post-Assembly Insertion Nuts / Stoppers for Aluminum Extrusions - Others HFS5 Series (Aluminum Extrusions 20, 25, 40 Square)

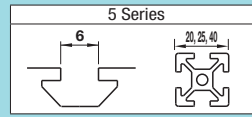

### Post-Assembly Insertion Lock Nuts with Leaf Springs



#### HNTRP5

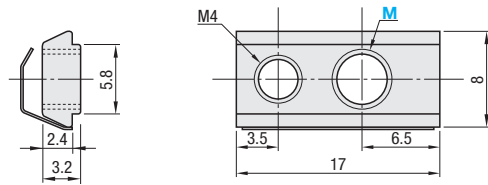

Reference Tightening Torque (N·m)	
M	1010 Carbon Steel
5	6.8

Part	Material	Surface Treatment
Main Body	1010 Carbon Steel	Trivalent Chromate
Wing Part	304 Stainless Steel	-

Part Number	M	Accessories	Volume Discount Rate			
			Unit Price 1~499 pc(s).	500~749	750~999	1000~
HNTRP5	5	M4 Set Screw for Locking				

### Post-Assembly Insertion Lock Nuts

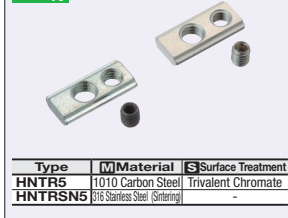

#### HNTR5 (1010 Carbon Steel) HNTRSN5 (316 Stainless Steel, Sintering)

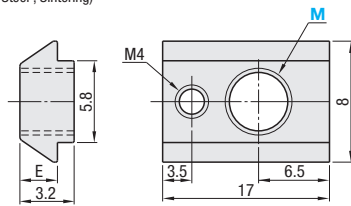

Reference Tightening Torque (N·m)	
M	1010 Carbon Steel / 316 Stainless Steel (Sintering)
5	6.8

Type	Material	Surface Treatment
HNTR5	1010 Carbon Steel	Trivalent Chromate
HNTRSN5	316 Stainless Steel (Sintering)	-

Part Number	M	E	Accessories	Volume Discount Rate			
				Unit Price 1~499 pc(s).	500~749	750~999	1000~
HNTR5 (1010 Carbon Steel)	3	4	5	2.4	M4x5 Set Screw for Locking 1 pc.		
HNTRSN5 (316 Stainless Steel, Sintering)				2.5			

Ordering Example: Part Number - M  
HNTR5 - 5  
HNTRP5 - 5

Days to Ship: [Configure Online](#)

### Post-Assembly Insertion Lock Nuts (HNTR)

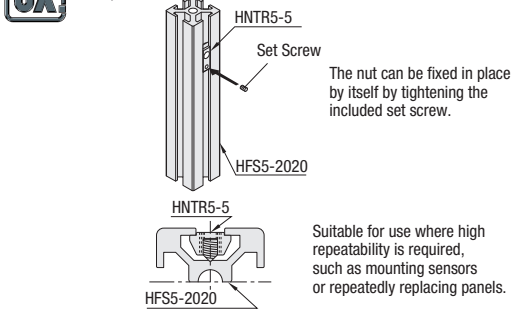

### Post-Assembly Insertion Lock Nuts with Leaf Springs (HNTRP)

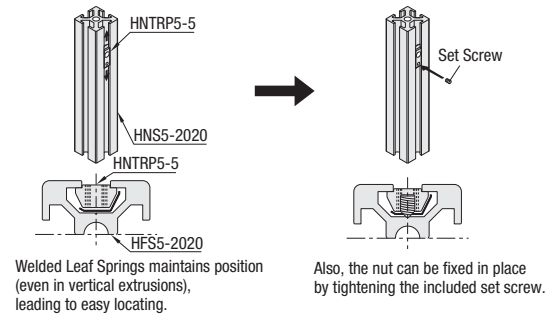

### Post-Assembly Insertion Short Nuts



#### HNTAJ5 PACK-HNTAJ5 (100/pkg.)

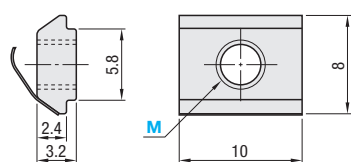

Overall length is shorter than Pre-Assembly Insertion Nuts HNTT. Suitable for installing sensors or other components closely together.

Ordering Example: Part Number - M  
HNTAJ5 - 5

Days to Ship: [Configure Online](#)

Part Number	M	HNTAJ5				PACK-HNTAJ5 (100/pkg.)			
		Unit Price 1~499 pc(s).	500~749	750~999	1000~	Unit Price 1 pkg.	2~4	5~9	10~
HNTAJ5 PACK-HNTAJ5	3 4 5								

## Pre-Assembly Insertion Screws / Post-Assembly Insertion Screws / Flanged Nuts HFS5 Series (Aluminum Extrusions 20, 25, 40 Square)

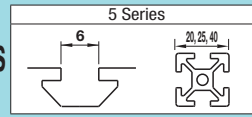

### Pre-Assembly Insertion Screws



#### HNTLSN5-5

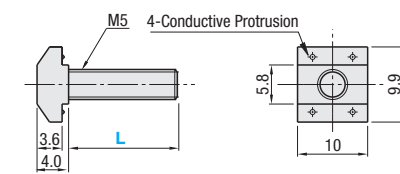

### Effective Length of Pre-Assembly Insertion Screws

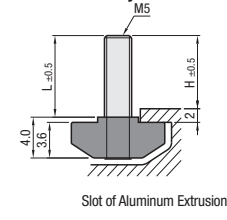

Part Number	L	H	Applicable Extrusion (Series)	Reference Tightening Torque (N·m)	Unit Price		Volume Discount Rate	
					1~299 pcs.	300~499	500~	
HNTLSN5-5	12 17	10.8 15.8	HFS5	6.8				

### Post-Assembly Insertion Screws



#### HATLSN5-4

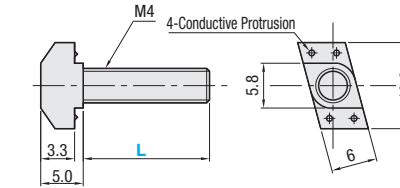

### Effective Length of Post-Assembly Insertion Screws

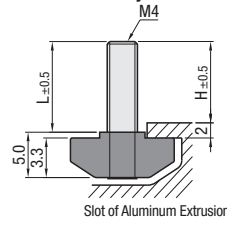

Part Number	L	H	Applicable Extrusion (Series)	Unit Price		Volume Discount Rate	
				1~299 pcs.	300~499	500~	
HATLSN5-4	12 17	11.7 16.7	HFS5				

### Flanged Nuts



#### HTDN

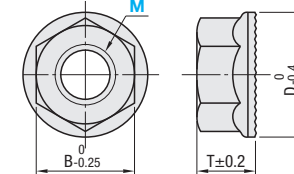

Part Number	Type	M	B	T	D	Unit Price		Volume Discount Rate	
						1~499 pc(s).	500~999	1000~	
HTDN (Stainless Steel)	4 5	7 8	4.2 5.5	10 12					

Ordering Example: Part Number - L  
HNTLSN5-5 - 12  
HTDN5

Days to Ship: [Configure Online](#)

