

Rubber / Sponge Gaskets

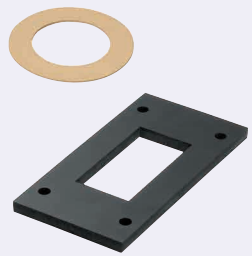

Type	Material	Hardness	Color
FRN	Nitrile Rubber (NBR Nitrile Rubber)	Shore A70	Black
FRC	Chloroprene Rubber (CR)	Shore A65	Black
FRCAN	Amber Color Rubber	Shore A45	Amber Color
FRSM	Silicon Rubber	Shore A70	Light Gray
FRAM	Silicon Rubber	Shore A50	Milky White
FRFF	Fluororubber (FPM)	Shore A80	Black
FSNC	Chloroprene Rubber Sponge	Asker C25	Black
FSNF	Fluororubber Sponge	Asker C35	Black
FSNA	Silicon Rubber Sponge	Asker C35	Orange
FREP	Ethylene Rubber (EPDM Synthetic Rubber)	Shore A65	Black

☞ Sponge Hardness: ASKER-C

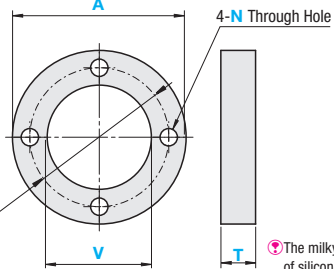

Select a shape from below.

☞ The milky white color of silicone rubber shore A50 is translucent.

Shape Selection

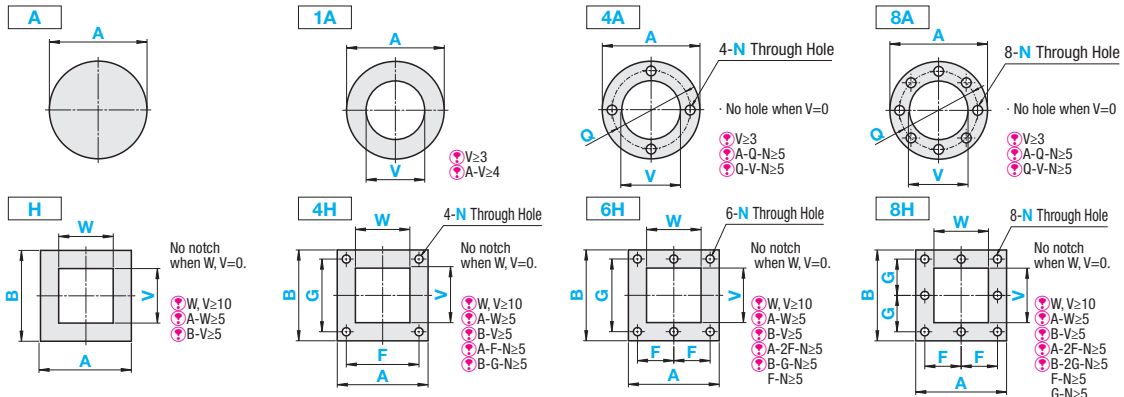

<Machining Limits>

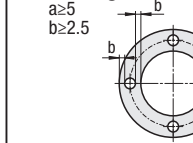

Accuracy Standards

Material	T Dimension Tolerance	Dimension Tolerance of A, B and V	A, B Dimension Tolerance
Rubber	1-3: ±0.3, 5: ±0.4, 10: ±0.6, 15-30: +2.0/-0.5	200mm or Less: ±0.5, 201-300: ±1.0, 301-500: ±1.5	190mm or Less: ±1.5, 191-390: ±2, 391 or More: ±3
Sponge	3, 5, 10		

☞ A, B dimension tolerance has been changed. Please refer to the accuracy standards above.

Type	Shape	Part Number		1mm Increment (A ≥ B ≥ T)						0.5mm Increment
		Rubber	Sponge	A	B	W	V	F	G	Q
FRN (Nitrile Rubber)	A	1		25-500 (When T=30, A ≥ 30)	25-500 (When T=30, B ≥ 30)	0.5mm Increment <Refer to Machining Limits and Condition Formula>				3-30
FRC (Chloroprene Rubber)	1A									
FRFF (Fluororubber)	4A	2								
FRSM (Silicon A70)	4A	3								
FRAM (Silicon A50)	8A	3								
FRCAN (Amber Color Rubber)	H	5								
FSNC (Chloroprene Rubber Sponge)	H	5								
FSNF (Fluororubber Sponge)	4H	10								
FSNA (Silicon Rubber Sponge)	4H	15								
FREP (Ethylene Rubber EPDM Synthetic Rubber A65)	8H	20	10							
		30								

☞ For FRFF (Fluororubber) with T dimension 15-30 maximum value for A and B is 300.



Alterations	1-Flat	2-Flat	Counterbore Hole
Code	SC	WSC	ZC
Spec.	Adds one flat. Applicable to Shape A and Shape 1A. [Ordering Code] SC100 SC=1mm Increment Shape A A/2 ≤ SC-A-2 Shape 1A A/2+V/2+2.5 < SC-A-2	Adds two flats. Applicable to Shape A and Shape 1A. [Ordering Code] WSC100 WSC=1mm Increment Shape A A/2 ≤ WSC-A-4 Shape 1A V+5 < WSC-A-4	Changes N (Through Hole) to Counterbore Hole. [Ordering Code] ZC-Z17.5-J15 Z, J=0.5mm Increment Z-N ≥ 4 T-J ≥ 2 ☞ Not available for Sponge Type.
Price Adder			

Ordering Example

Part Number	FRN	4H	3	A300	B200	W200	V100	F250	G150	N11
-------------	-----	----	---	------	------	------	------	------	------	-----

Days to Ship [Configure Online](#)

Price [Configure Online](#)

Shape Machining Charge

Shape Code	Price	Shape Code	Price
A		H	
1A		4H	
4A		6H	
8A		8H	

Nitrile Rubber / Chloroprene Rubber / Silicon Rubber

Part Number	Type	T	A	Unit Price							
				B	25-100	101-200	201-300	301-400	401-500		
Nitrile Rubber FRN	1	1	25-100								
			101-200								
			201-300								
			301-400								
			401-500								
			Chloroprene Rubber FRC	3	3	25-100					
						101-200					
						201-300					
						301-400					
						401-500					
Amber Color Rubber FRCAN	5	5				25-100					
						101-200					
						201-300					
						301-400					
						401-500					
			Ethylene Rubber FREP	20	20	25-100					
						101-200					
						201-300					
						301-400					
						401-500					

Fluororubber

Part Number	Type	T	A	Unit Price							
				B	25-100	101-200	201-300	301-400	401-500		
Fluororubber FRFF	5	5	25-100								
			101-200								
			201-300								
			301-400								
			401-500								
			Chloroprene Rubber Sponge FSNC	3	3	25-100					
						101-200					
						201-300					
						301-400					
						401-500					
Fluororubber Sponge FSNF	5	5				25-100					
						101-200					
						201-300					
						301-400					
						401-500					
			Silicon Rubber Sponge FSNA	5	5	25-100					
						101-200					
						201-300					
						301-400					
						401-500					

Chloroprene Rubber Sponge / Fluororubber Sponge / Silicon Rubber Sponge

Part Number	Type	T	A	Unit Price							
				B	25-100	101-200	201-300	301-400	401-500		
Chloroprene Rubber Sponge FSNC	3	3	25-100								
			101-200								
			201-300								
			301-400								
			401-500								
			Fluororubber Sponge FSNF	5	5	25-100					
						101-200					
						201-300					
						301-400					
						401-500					
Silicon Rubber Sponge FSNA	5	5				25-100					
						101-200					
						201-300					
						301-400					
						401-500					