

[High Precision] Motorized XY-Axis - Cross Roller

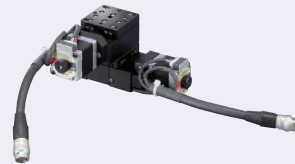

■ **Features:** XY-Axis Stage excellent in lightweight, compactness and accuracy.

■ **XY-Axis**



M Material: Aluminum Alloy
S Surface Treatment: Black Anodize
A Accessory: XYCR415: SCB3-16 (4 pcs.)
 XYCR620: SCB4-16 (4 pcs.)

☞ For Controllers, Handset Terminals, see P. 1-1735-93-P, 1-1735-94



XYCR415-C

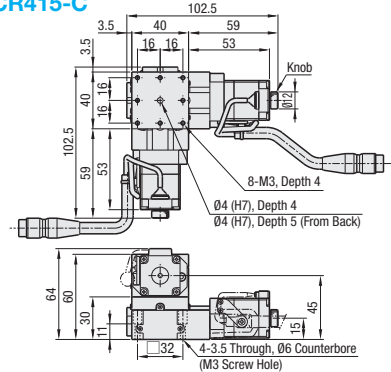

XYCR415-PA

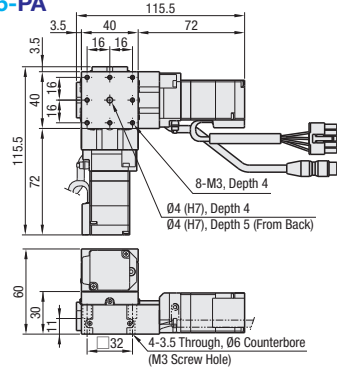

XYCR620-C

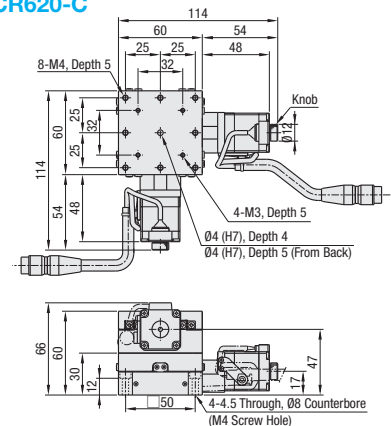

XYCR620-F

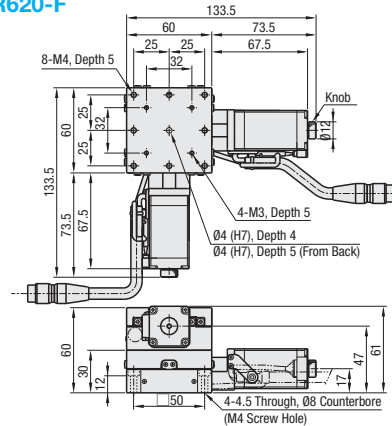

XYCR620-G

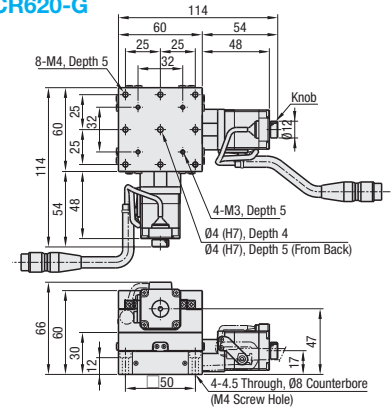

XYCR620-PA

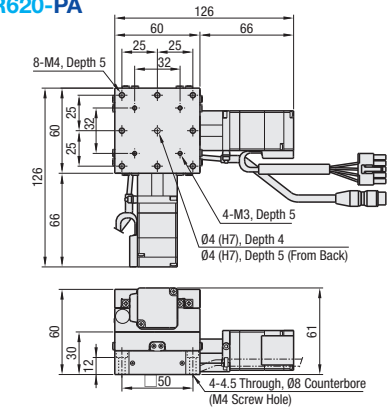

☞ See the CAD data for detailed dimensions.

☞ For CAD data, see the MISUMI website.

Part Number	Type	No.	Motor	Cable	Mechanical Standards			Accuracy Standards *2					
					Stage Surface (mm)	Travel Distance (mm)	Weight *1 (kg)	Unidirectional Positioning Accuracy	Moment Rigidity (N·m/cm)			Pitching	Yawing
XYCR		415	C (Standard) PA* (α-Step)	N (Cable not included (separately sold)) P* (Cable for α-Step Motor) For cables separately sold, see MSCB_ option on P. 1-1735-95	40×40	15	0.6	10µm or less	0.33	0.44	0.37	25"	20"
		620	C (Standard) F (High Torque) G (High Resolution) PA* (α-Step)		60×60	20	0.9	5µm or less / Full Stroke	0.15	0.12	0.07	20"	15"

* When the Motor Option PA is selected, the driver is included with the Set. The cable is available for Option P and is unavailable for Option N (Cable not included).

*1. The value is for C Type of Motor.

*2. The above accuracy standards of Unidirectional Positioning Accuracy and Moment Rigidity are for a single axis.



Ordering Example
Part Number - **Motor** - **Cable**
 XYCR415 - C - N



Configure Online

■ **Common Specifications**

No.	415	620
Feed Screw	Ball Screw 06, Lead 1	Ball Screw 08, Lead 1
Guide	Cross Roller Guide	
Positioning repeatability	±0.5µm	±0.3µm
Load Capacity*3	44.1N	
Lost Motion	1µm or less	
Parallelism	30µm or less	
Straightness	3µm or less	
Motion Parallelism	10µm or less	

* The above specifications are for a single axis.
 *3. The above load capacity value is for XY-Axis.

■ **Connector Pin Configuration**

• Motor Code: C (Standard), F (High Torque), G (High Resolution)
 General Connector Pin Configuration

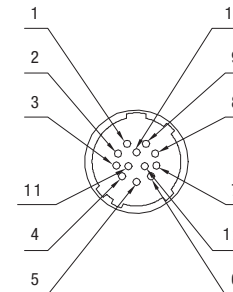

• Motor Code: PA (α-Step)
 Motor Cable Part Number: CC030VA2R2
 Sensor Pin Configuration

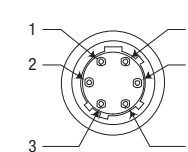

■ **Max. Speed**

No.	Motor	(mm/sec)
415	C	10
	PA	10
620	C	20
	F	20
	G	20
	PA	20

☞ Note that the speed and positioning time differ depending on the current condition of use. The speed and positioning time are not guaranteed values but reference values provided by MISUMI.

■ **Motor/Cable Application Table**

Motor	Cable
C, F, G	N (Not Provided)
PA	P

☞ For the cable for C, F or G, see MSCB_ on P. 1-1735-95

■ **Wiring Diagram**

• Motor Code: C (Standard), F (High Torque), G (High Resolution)
 General Connector Pin Configuration

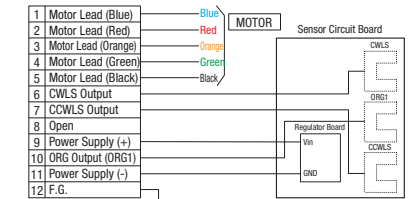

• Motor Code: PA (α-Step)
 Sensor Connecting Diagram



■ **Electrical Specifications**

Motor	Type	C	F	G	PA
		Standard	High Torque	High Resolution	Stepping-out Prevention
Motor	Part Number	C005C-90215P	PK525HPB-C1	PK523HPMB-C1	α-Step Motor ARM24SAK
	Step Angle	0.72°	0.72°	0.36°	0.36° (When 1000P/R is set)
	Driver Part Number				ARD-K
Resolution (Pulse)	Full/Half	2µm/1µm	2µm/1µm	1µm/0.5µm	1µm (When 1000P/R is set)
	Micro Step	0.1µm (upon 1/20 partitioned)	0.1µm (upon 1/20 partitioned)	0.05µm (upon 1/20 partitioned)	-
Connector	Part Number	HR10A-10J-12P (Hirose Electric Co., LTD.)			HR10A-7J-6P (Hirose Electric Co., LTD.)
	Compatible Receptacle Connector	HR10A-10P-12S (Hirose Electric Co., LTD.)			HR10A-7P-6S (Hirose Electric Co., LTD.)
	Limit Sensor	Provided			
Sensor	Home Position Sensor (ORG1)	Provided			
	Slit Home Origin Sensor (ORG2)	Not Provided			
	Part Number	Photomicrosensor: EE-SX4320 (OMRON Corp.)			
	Power Supply Voltage	DC5~24V ±10%			
	Current Consumption	60mA or less			
	Control Output	NPN Open Collector Output DC5~24V, 8mA or less Residual Voltage 0.3V or less (when load current is 2mA) Detecting (Dark): Output Transistor OFF (Non-Conducting)			

☞ Sensors with Part Number EE-SX4134 will be discontinued and replaced by next-generation products with Part Number EE-SX4320 from November 2018.

■ **Timing Chart**

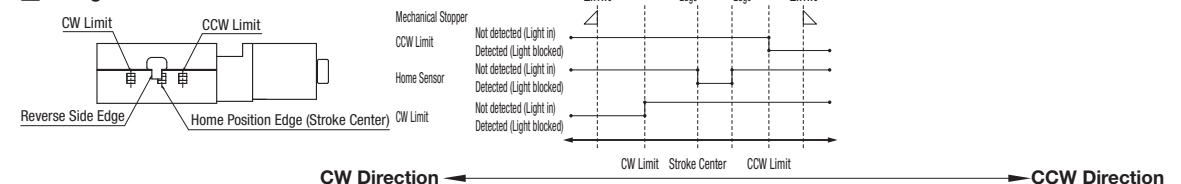

Travel Distance (mm)	Reference Position	Mechanical Limit	CW Limit	Home Position Edge Stroke Center	Other Signal Edge	CCW Limit	Mechanical Limit
15	Homing Position	8.5	7.7	0	2	7.7	8.5
20	Homing Position	11	10.5	0	5	10.5	11

☞ Homing Routine Above: When MSCTL102/112 Series controller is used and when the Homing Routine Type 4 is executed.

☞ The coordinates shown are design values. There may be approx. ±0.5mm misalignment on the physical dimensions.

☞ For details about Homing, see P. 1-1735-97