

[High Precision] Motorized XYZ-Axis - Linear Ball, CAVE-X POSITIONER



For CAD data, see the MISUMI website.

Features: Have high rigidity and compactness in width. Support 30~50mm of travel distance.

XYZCVL (w/o Cover)



XYZCVLC (with Cover)



M Material: 440C Stainless Steel
S Surface Treatment: Electroless Nickel Plating
A Accessory: SCB4-14 (8 pcs.)

For Controllers, Handset Terminals, see P.1-1735-93-P.1-1735-94

RoHS 10

XYZCVL630

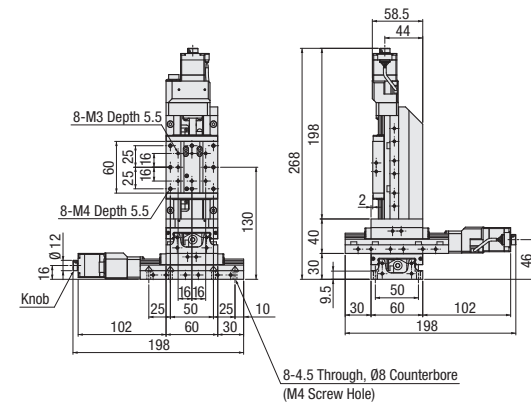

XYZCVLC630

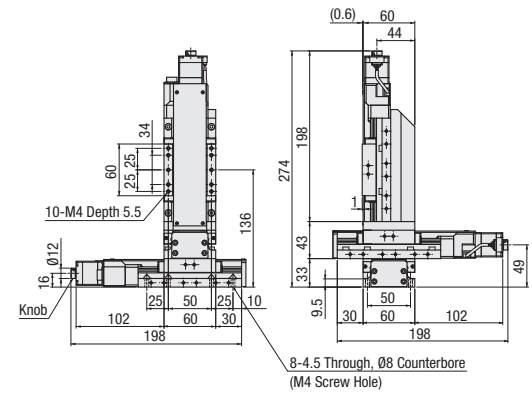

XYZCVL650

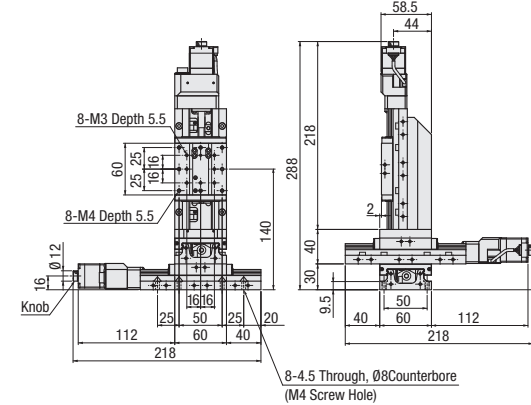

XYZCVLC650

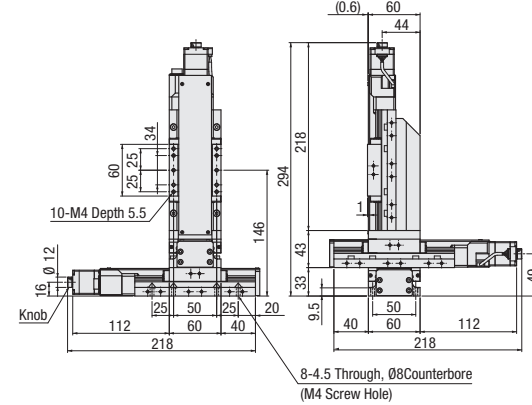

Additional Positions for Mounting Origin Sensor (Options)

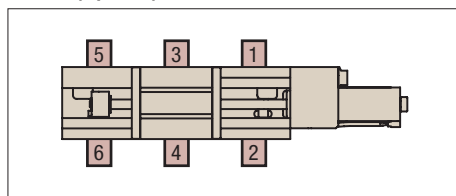

The above diagrams are for stages incorporating Motor C. For detailed dimensions about stages incorporating Motor F, G, MA, PA or U, see the relevant CAD data.

Part Number	Type	No.	Lead (mm)	Sensor	Motor	Cable	Mechanical Standards			Accuracy Standards		
							Stage Surface (mm)	Travel Distance (mm)	Weight (kg) ²	Unidirectional Positioning Accuracy for a single axis stage horizontally placed	Pitching	Yawing
XYZCVL (w/o Cover)		630	1 (Lead 1mm)	N (W/o Sensor) 1 (CCW Right) 2 (CW Left) 3 (Right-center) 4 (Left-center) 5 (CW Right) 6 (CW Left) *The Limit Sensor is built-in.	C (Standard) F (High Torque) G (High Resolution) MA* (With Electromagnetic Brake) PA* (α-Step) U* (Servo Motor, Amplifier)	N (Cable not included (separately sold)) M* (For Motor with Electromagnetic Brake) P* (For α-Step) U* (For Servo Motor) *For combination of motors and cables, see the table below.	60×60	30	4.6 (4.7 ³)	5μm	20"	15"
XYZCVLC (with Cover)	650	50						4.9 (5.0 ³)				

*1. When the Motor Option M or P is selected, the driver is included with as the Set. When the Option U is selected, the Amplifier is included with. The cable is available for Option MA, PA, U and is unavailable for Option N (Cable not included). *2. The value is for C Type of Motor. *3. Values in () are for stages with Cover. *The accuracy specifications above are certified for single-axis horizontal mounting orientation.



Ordering Example: **Part Number** - **Lead** - **Sensor** - **Motor** - **Cable**
 XYZCVL630 - 1 - N - C - N



Days to Ship [Configure Online](#)

Motor/Cable Application Table

Motor	Cable
C, F, G	N (Not Provided)
MA	M
PA	P
U	U

For the cable for C, F or G, see MSCB_ on P.1-1735-95

Max. Speed

Motor	(mm/sec)
C	30
F	35
G	25
MA	25
PA	40
U	50

Note that the speed and positioning time differ depending on the current condition of use. The speed and positioning time are not guaranteed values but reference values provided by MISUMI.

Common Specifications

Feed Screw	Ball Screw Ø8, Lead 1
Guide	Linear Ball Guide
Resolution	Full 2μm Half 1μm Fine (At 1/20) 0.1μm
Max. Speed	20mm/sec
Positioning repeatability	±0.5μm
Load Capacity ⁴	68.6N
Lost Motion	1μm
Backlash	1μm
Straightness	3μm
Parallelism	15μm
Motion Parallelism	10μm

The value differs depending on the type of motor. For details, see P.1-1735-15. The above specifications table is for a single axis stage placed flatly. *4. The above load capacity value is for Z-Axis.

Connector Pin Configuration

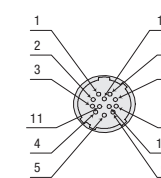

Wiring Diagram

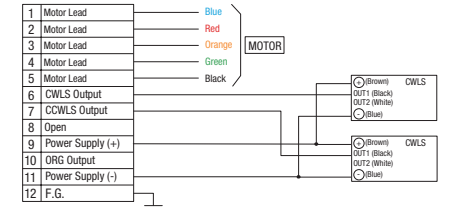

The above is the connector pin configuration / wiring diagram for C, F, G. For connector pin configuration / wiring for other types of motor, see P.1-1735-16.

Electrical Specifications

Motor	Type	C	F	G	MA	PA	U
		Standard	High Torque	High Resolution	With Electromagnetic Brake	Stepping-out Prevention	High Speed
			5-Phase Stepping Motor 0.75A/Phase			α-Step Motor	AC Servo Motor
	Step Angle	0.72°	0.72°	0.36°	0.72°	0.36° (When 1000P/R is set)	18-bit Encoder (262144P/R)
Connector	Applicable Receptacle Connector	HR10A-10P-12S (73) (Hirose Electric Co., LTD.)			5559-06R-210 (Molex Japan LLC)	43020-1000 (Molex Japan LLC)	Motor Cable JN4FT04SJ1-R (Japan Aviation Electronics Industry, Ltd.) Encoder: 1674320-1 (Tyco Electronics Japan G.K.)
Sensor	Limit Sensor	Provided					
	Home Sensor	Not Provided by standard (Photomicrosensor PM-L25 (Panasonic Industrial Devices SUNX Co., Ltd.) is available as the option.)					
	Near Home Sensor	-					
	Power Supply Voltage	DC5~24V±10%					
	Current Consumption	45mA or less (15mA or less per sensor)					
Control Output	NPN Open Collector Output DC30V or less, 50mA or less Residual Voltage 2V or less (when load current is 50mA) Residual Voltage 1V or less (when load current is 16mA)						
Output Logic	Detecting (Dark): Output Transistor OFF (Non-Conducting)						

Sensors with Part Number PM-□24 are to be discontinued and replaced by next-generation products with Part Number PM-□25 from April 2017.

Timing Chart

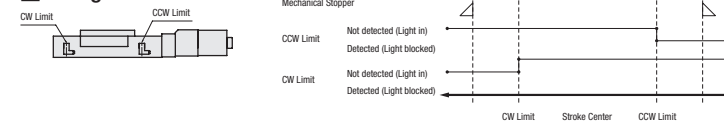

(Unit: mm) CW Direction ← → CCW Direction

	Reference Position	Mechanical Limit	CW Limit	CCW Limit	Mechanical Limit
XYZCVL_630	Stroke Center	17.5	15.5	15.5	17.5
XYZCVL_650	Stroke Center	27.5	25.5	25.5	27.5

The coordinates shown are design values. There may be approx. ±0.5mm misalignment on the physical dimensions.

For details about Homing, see P.1-1735-97

Recommended Homing Method

Type5	After detection is executed in the CCW direction, the process of detecting in the CW direction is begun based on the CWLS signal.
Type6	After detection is executed in the CW direction, the process of detecting in the CCW direction is begun based on the CWLS signal.
Type11	After Type 5 is executed, the process of detecting in the CCW direction is begun based on the TIMING signal.
Type12	After Type 6 is executed, the process of detecting in the CW direction is begun based on the TIMING signal.