

MOTORIZED STAGES XY-AXIS LINEAR BALL CAVE-X POSITIONER

[High Precision] Motorized XY-Axis - Linear Ball, CAVE-X POSITIONER



■ **Features:** Have high rigidity and compactness in width. Support 30~75mm of travel distance.

☉ For CAD data, see the MISUMI website.

■ XY-Axis: XYCVL (w/o Cover)

■ XY-Axis: XYCVLC (with Cover)

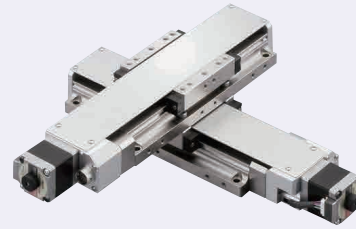
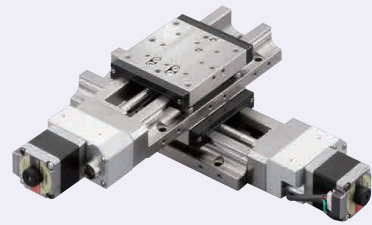

M Material: 440C Stainless Steel
S Surface Treatment: Electroless Nickel Plating
A Accessory: SCB4-14 (8 pcs.)
RoHS10

☉ For Controllers, Handset Terminals, see P. **1**-1735-93~P. **1**-1735-94

XYCVL (w/o Cover)

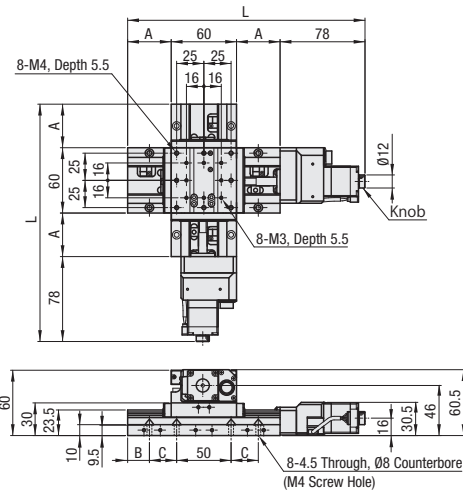

XYCVLC (with Cover)

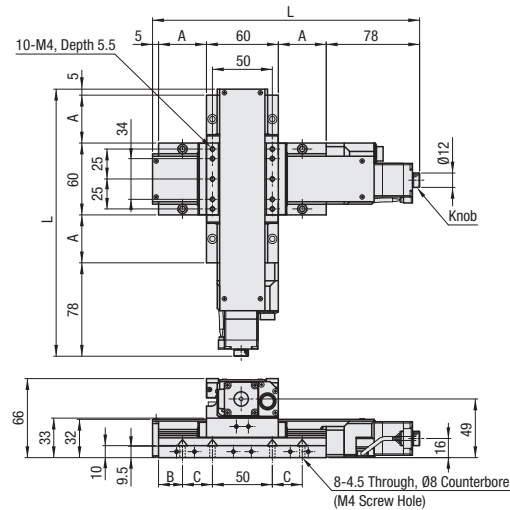

Additional Position for mounting Home Sensor (Option)

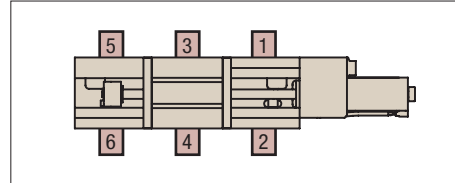

☉ See the CAD data for detailed dimensions.

■ Dimension Table

Part Number	L	A	B	C
Type	No.			
XYCVL	630	198	30	10
	650	218	40	20
	675	243	52.5	7.5

Part Number	L	A	B	C
Type	No.			
XYCVLC	630	203	30	10
	650	223	40	20
	675	248	52.5	7.5

Part Number	Lead (mm)	Sensor	Motor	Cable	Mechanical Standards			Accuracy Standards			
					Stage Surface (mm)	Travel Distance (mm)	Weight (kg)	Unidirectional Positioning Accuracy (for a single axis)	Pitching	Yawing	
XYCVL (w/o Cover)	630	1	N (W/o Sensor) 1 (CCW Right) 2 (CCW Left) 3 (Right-center) 4 (Left-center) 5 (CW Right) 6 (CW Left)	C (Standard) F (High Torque) G (High Resolution) MA ¹ (With Electromagnetic Brake) PA ¹ (α-Step) U ¹ (Servo Motor, Amplifier)	N (Cable not included (separately sold)) M (For Motor with Electromagnetic Brake) P ¹ (For α-Step) U ¹ (For Servo Motor)	60×60	30	2.6 (2.7 ²)	5μm	20"	15"
	650	2					50	2.8 (2.9 ²)			
XYCVLC (with Cover)	675	2	75	3.1 (3.3 ²)	7μm						

*1. For motor options MA and PA, the driver is included in the set. For motor option U, the amplifier is included in the set. With motor options MA, PA and U, the selectable cable options are M, P and U, respectively and exclusively. Note that the cable option N is not selectable.

*2. Values in () are for stages with Cover.

☉ The accuracy specifications above are certified for single-axis horizontal mounting orientation.

Ordering Example

Part Number - Lead - Sensor - Motor - Cable

XYCVL630 - 1 - N - C - N

XYCVLC675 - 2 - N - U - U

Days to Ship **Configure Online**

■ Motor/Cable Application Table

Motor	Cable
C, F, G	N
MA	M
PA	P
U	U

■ Max. Speed

Motor	(mm/sec)
C	30
F	35
G	25
MA	25
PA	40
U	50

☉ Note that the speed and positioning time will vary depending on the usage conditions. The values shown here are MISUMI's reference values. Operation at these values is not guaranteed.

■ Common Specifications

Feed Screw	Ball Screw Ø8, Lead 1	Ball Screw Ø8, Lead 2	
Guide	Linear Ball Guide		
Resolution	Full	2μm	4μm
	Half	1μm	2μm
	Fine (At 1/20)	0.1μm	0.2μm
Max. Speed	30mm/sec	35mm/sec	
Positioning repeatability*	±0.5μm		
Load Capacity	98N		
Lost Motion*	15μm		
Backlash*	1μm		
Straightness*	3μm		
Parallelism*	15μm		
Motion Parallelism*	10μm		

* The above accuracy standard is for a single axis.

☉ The figures in () will vary depending on the motor. For details, see page P. **1**-1735-15.

■ Connector Pin Configuration

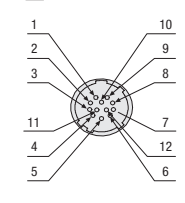

■ Wiring Diagram

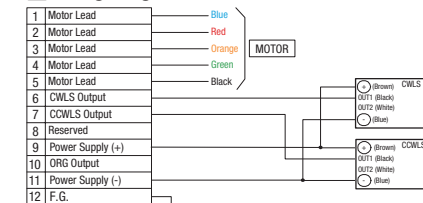

☉ The above is the connector pin configuration / wiring diagram for F, G. For connector pin configuration / wiring for other types of motors, see P. **1**-1735-16

■ Electrical Specifications

Motor	Type	C	F	G	MA	PA	U
		Standard	High Torque	High Resolution	With Electromagnetic Brake	Tuningless	High Speed
		5-Phase Stepping Motor 0.75A/Phase (Oriental Motor Co., Ltd.)				α-Step Motor	AC Servo Motor
	Step Angle	0.72°	0.72°	0.36°	0.72°	0.36° (When 1000P/R is set)	18-bit Encoder (262144P/R)
	Applicable Receptacle Connector	HR10A-10P-12S (73) (Hirose Electric Co., LTD.)			5559-06R-210 (Molex Japan LLC)	43020-1000 (Molex Japan LLC)	Motor Cable: JN4FT04S, J1-R (Japan Aviation Electronics Industry, Ltd.) Encoder: 1674320-1 (Tyco Electronics Japan G.K.)
Sensor	Limit Sensor	Provided					
	Home Sensor	Not Provided by standard (Photomicrosensor PM-L25 (Panasonic Industrial Devices SUNX Co., Ltd.) is available as the option.)					
	Near Home Sensor	-					
	Power Supply Voltage	DC5~24V ±10%					
	Current Consumption	45mA or less (15mA per Sensor)					
	Control Output	NPN Open Collector Output DC30V, 50mA or less Residual Voltage 2V or less (when load current is 50mA) Residual Voltage 1V or less (when load current is 16mA)					
	Output Logic	Detecting (Dark): Output Transistor OFF (Non-Conducting)					

☉ Sensors with Part Number PM-□24 are to be discontinued and replaced by next-generation products with Part Number PM-□25 from April 2017.

■ Timing Chart

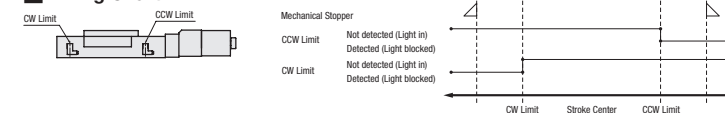

(Unit: mm) CW Direction ← → CCW Direction

Reference Position	Mechanical Limit	CW Limit	CCW Limit	Mechanical Limit
XCVL_6100 Stroke Center	52.5	50.5	50.5	52.5
XCVL_6150 Stroke Center	77.5	75.5	75.5	77.5
XCVL_6200 Stroke Center	102.5	100.5	100.5	102.5
XCVL_6300 Stroke Center	152.5	150.5	150.5	152.5

☉ The coordinates shown are design values. There may be approx. ±0.5mm misalignment on the physical dimensions.

☉ For details about Homing, see P. **1**-1735-67

■ Recommended Method for Return to Origin

Type	Description
Type5	Detect in the direction of CCW and perform detected process for CW edge of CWLS signal.
Type6	Detect in the direction of CW and perform detected process for CCW edge of CWLS signal.
Type11	After finished type5, perform detected process for CCW edge of TIMING signal.
Type12	After finished type6, perform detected process for CW edge of TIMING signal.