

MOTORIZED STAGES XY-AXIS LINEAR BALL CAVE-X POSITIONER

[High Precision] Motorized XY-Axis - Linear Ball, CAVE-X POSITIONER

Compact



For CAD data, see the MISUMI website.

Features: XY-Axis Type with High Rigidity, Compactness in width and the Space-saving design for the overall length.

XY-Axis, Compact



M Material: 440C Stainless Steel
S Surface Treatment: Electroless Nickel Plating
A Accessory: SCB4-12 (4 pcs.)



For Controllers, Handset Terminals, see P.1-1735-93-P.1-1735-94

XYCV620-C

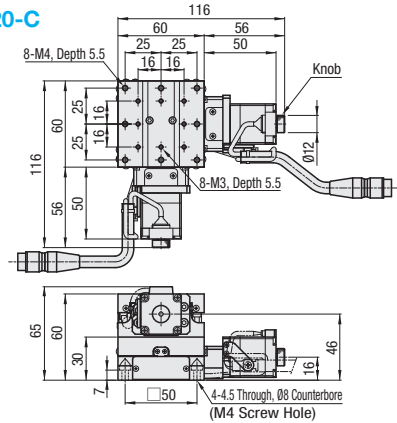

XYCV630-C

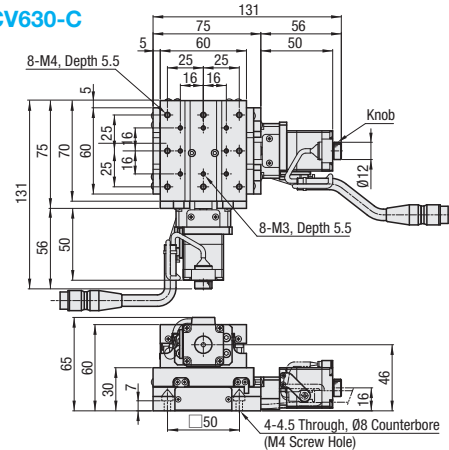

XYCV620-F

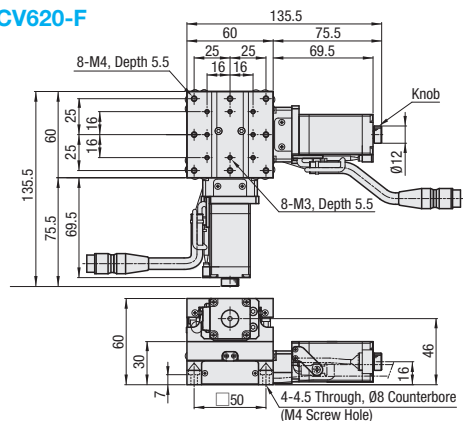

XYCV630-F

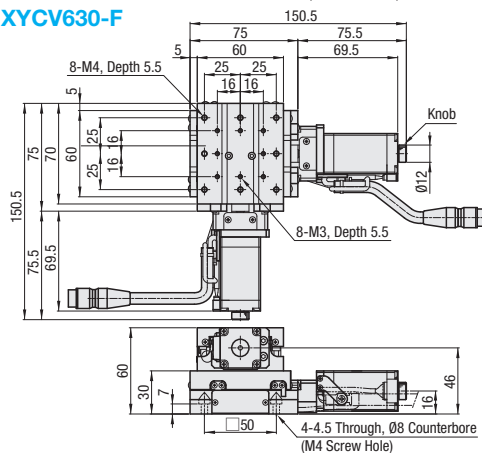

XYCV620-G

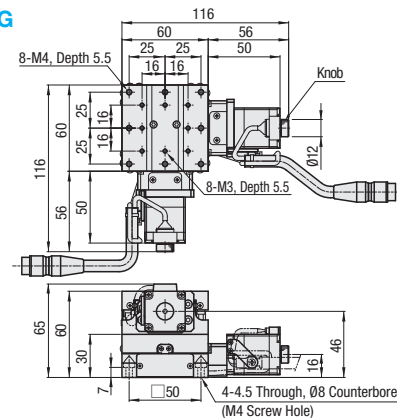

XYCV630-G

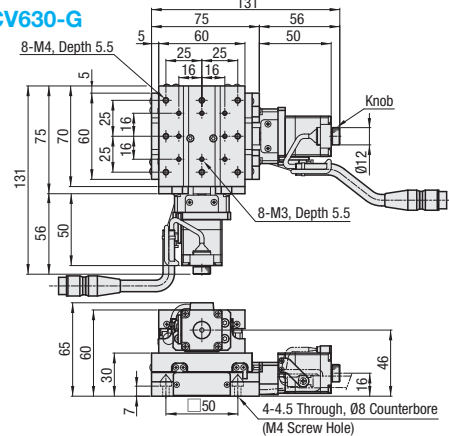

For the detailed dimensions of CAVE-X Positioner with the Motor PA installed, see the applicable CAD data.

Part Number	Type	No.	Motor	Cable	Mechanical Standards			Accuracy Standards		
					Stage Surface (mm)	Travel Distance (mm)	Weight ^{*2} (kg)	Unidirectional Positioning Accuracy (for a single axis stage horizontally placed)	Pitching	Yawing
XYCV		620	C (Standard) F (High Torque) G (High Resolution)	N (Cable not included (separately sold)) M (For Motor with Electromagnetic Brake) P (For α-xt) * For combination of motors and cables, see the table below.	60×60	20	1.6	5μm	20"	15"
		630	MA [*] (With Electromagnetic Brake) PA [*] (α-Step)		60×70	30	1.8			

*1. For motor options MA and PA, the driver is included in the set. With motor options MA and PA, the selectable cable options are M and P, respectively and exclusively. Note that the cable option N is not selectable.
 *2. The value is for C Type of Motor.



Ordering Example
 Part Number - Motor - Cable
 XYCV620 - C - N
 XYCV630 - PA - P



Days to Ship

Configure Online

Motor/Cable Application Table

Motor	Cable
C, F, G	N (Not Provided)
MA	M
PA	P

For the cable for C, F or G, see MSCB_on P.1-1735-95

Max. Speed

Motor	(mm/sec)
C	30
F	35
G	25
MA	25
PA	40

Note that the speed and positioning time differ depending on the current condition of use. The speed and positioning time are not guaranteed values but reference values provided by MISUMI.

Common Specifications

Feed Screw	Ball Screw Ø8, Lead 1	
Guide	Linear Ball Guide	
Resolution ^{*3}	Full	2μm/Pulse (1μm/Pulse) ^{*4}
	Half	1μm/Pulse (0.5μm/Pulse) ^{*4}
	Fine Feed (upon 1/20 partitioned)	0.1μm (0.05μm)
Max. Speed ^{*5}	20mm/sec (30mm/sec) ^{*5} (Pulse Rate: 5kHz)	
Positioning repeatability	±0.5μm	
Load Capacity ^{*7}	39.2N	
Lost Motion	1μm	
Backlash	1μm	
Straightness	3μm	
Parallelism	15μm	
Motion Parallelism	10μm	

*3 The above specifications are for a single axis.
 *4 This represents the travel distance of stage per one pulse signal.
 *5 The values in () are for Motor Option G (High Resolution).
 *6 This represents the max. speed that can be driven by the recommended controller switched to Full Step mode, with the max. load applied. (The value differs depending on the current driving controller and the current load.)
 *7 The values in () are for Motor Option F (High Torque).
 *8 The value differs depending on the motor option.
 *9 The above load capacity value is for XY-Axis.

Connector Pin Configuration

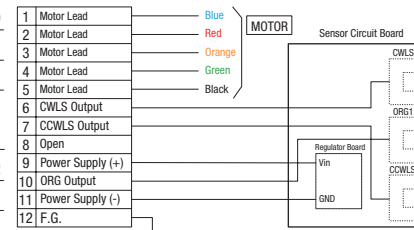
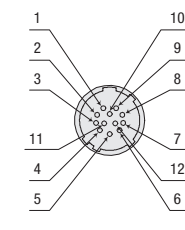

Electrical Specifications

Motor	Type	C	F	G	MA	PA	
		Standard	High Torque	High Resolution	With Electromagnetic Brake	Tuningless	
	Step Angle	0.72°	0.72°	0.36°	0.72°	0.36° (When 1000P/R is set)	
	Connector	Applicable Receptacle Connector			HR10A-10P-12S(73)(Hirose Electric Co., LTD.)	5559-06R-210 (Molex Japan LLC)	43020-1000 (Molex Japan LLC)
Sensor	Limit Sensor	Provided					
	Home Sensor	Photomicrosensor: EE-SX4320 (OMRON Corp.)					
	Near Home Sensor	-					
	Power Supply Voltage	DC5-24V ±10%					
	Current Consumption	60mA or less in Total					
	Control Output	NPN Open Collector Output DC5-24V, 8mA or less Residual Voltage 0.3V or less (when load current is 2mA)					
	Output Logic	Detecting (Dark): Output Transistor OFF (Non-Conducting)					

Sensors with Part Number EE-SX4134 will be discontinued and replaced by next-generation products with Part Number EE-SX4320 from November 2018.

Timing Chart

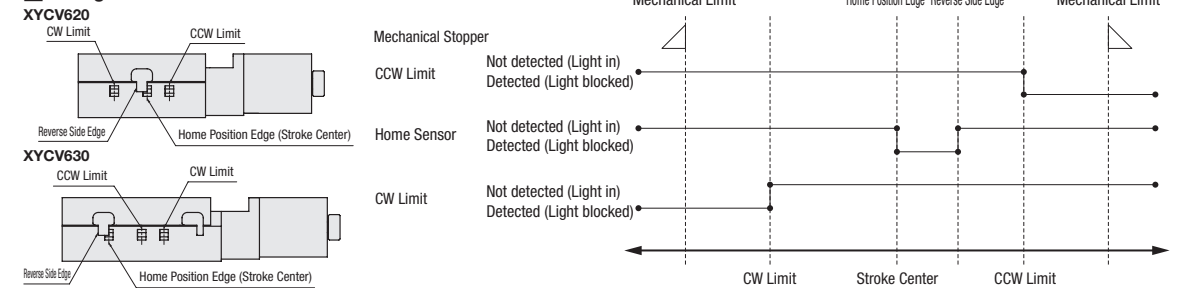

(Unit: mm) CW Direction ← → CCW Direction

Reference Position	Mechanical Limit	CW Limit	Home Position Stroke Center	Other Signal Edge	CCW Limit	Mechanical Limit
XYCV620 Homing	11	10.5	0	5	10.5	13
XYCV630 Homing	16	15.5	0	5	15.5	18

Recommended Homing Method

Type3	After detection is executed in the CCW direction, the process of detecting in the CW direction is begun based on the ORG signal.
Type4	After detection is executed in the CW direction, the process of detecting in the CCW direction is begun based on the ORG signal.
Type9	After Type 3 is executed, the process of detecting in the CCW direction is begun based on the TIMING signal.
Type10	After Type 4 is executed, the process of detecting in the CW direction is begun based on the TIMING signal.

Homing mentioned here means that Homing Routine Type 4 is executed by using the MSCTL102 Series controller.
 The coordinates shown are design values. There may be approx. ±0.5mm misalignment on the physical dimensions.
 For details about Homing, see P.1-1735-97