

# [Standard] Dovetail Slide, Rack & Pinion Long

Other Information about Stages  
 Stage Selection Table P.1639, P.1640  
 New Products P.1641  
 About Standard Stages P.1642  
 Overview, Technical Information P.1643, P.1644

Other Information about Stages  
 Stage Selection Table P.1639, P.1640  
 New Products P.1641  
 About Standard Stages P.1642  
 Overview, Technical Information P.1643, P.1644

Feature: Economically priced long stroke Rack & Pinion stages. Existing Products: XLWG, ZLWG (P.1669, 1703)

X-Axis



XDTLS

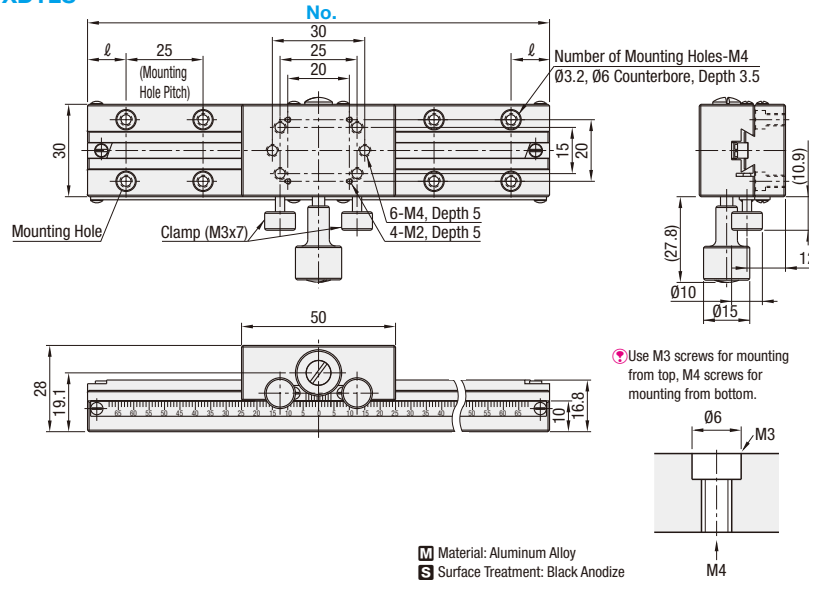

M Material: Aluminum Alloy  
 S Surface Treatment: Black Anodize

RoHS 10

X-Axis Stages High Precision Stage Existing Product: XLWG (P.1669)

Part Number Type	No.	Stage Surface (mm)	Travel Distance (mm)	Travel per Knob Rotation (mm)	Number of Mounting Holes (Qty.)	l	Load Capacity (N)		Travel Accuracy Straightness	Weight (kg)	Unit Price 1~4 pc(s).	
							Horizontal	Vertical				
XDTLS	80	30x50	±30	16.7	6	15	29.4	14.7	50µm	0.15		
	100		±40		8							0.18
	150		±65		12							0.23
	200		±90		16							0.30

Resolution (Vernier Scale Indication): 0.1 mm/division

Knob Cover HDCVR15 (Sold Separately): Ø15 knobs can be increased in diameter by installing the cover. P.1666

For orders larger than indicated quantity, please request a quotation.

Ordering Example Part Number XDTLS100

Days to Ship

Configure Online

Example Parallelism Inspection Unit

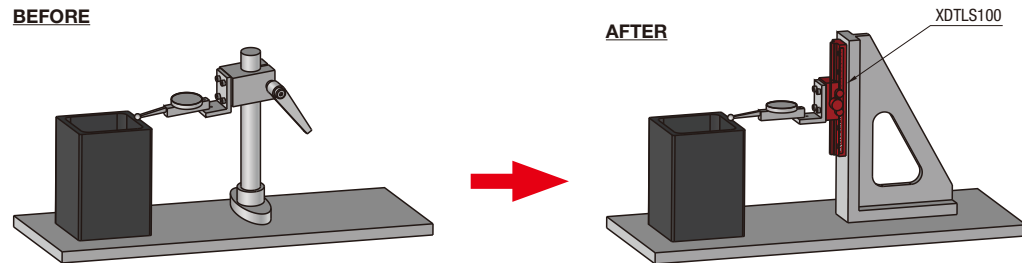

Increased Adjustment Accuracy: Fine adjustment of the dial indicator tip can be achieved quantitatively, not with experience.  
 Improved Safety: Installing a dial indicator onto the stage prevents from falling.

Z-Axis



ZDTLS80

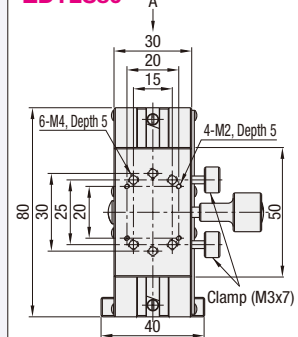

Arrow View A

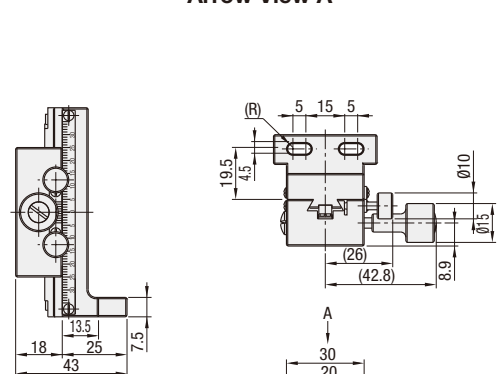

ZDTLS100

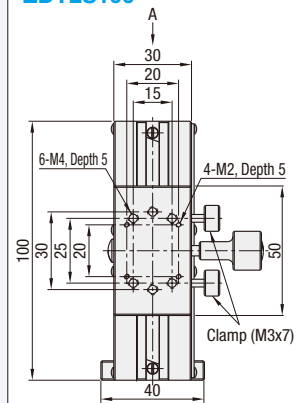

ZDTLS150

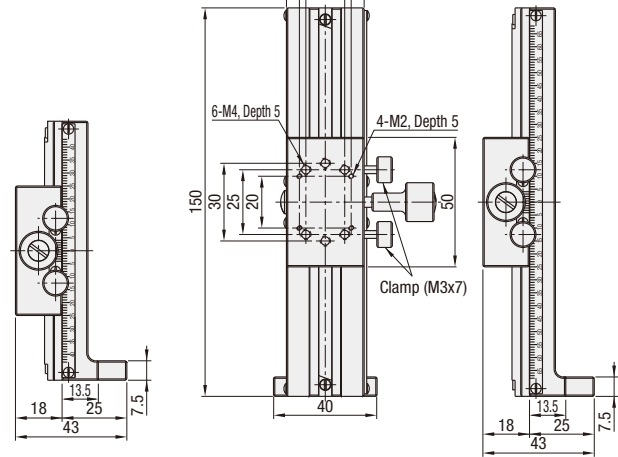

M Material: Aluminum Alloy  
 S Surface Treatment: Black Anodize

RoHS 10

Z-Axis Stages High Precision Stage Existing Product: ZLWG (P.1703)

Part Number Type	No.	Stage Surface (mm)	Travel Distance (mm)	Travel per Knob Rotation (mm)	Load Capacity (N)	Travel Accuracy Straightness	Weight (kg)	Unit Price 1~4 pc(s).
	100	±35	0.19					
	150	±65	0.24					

Resolution (Vernier Scale Indication): 0.1 mm/division

Knob Cover HDCVR15 (Sold Separately): Ø15 knobs can be increased in diameter by installing the cover. P.1666

For orders larger than indicated quantity, please request a quotation.

Ordering Example Part Number ZDTLS100

Days to Ship

Configure Online

Example Welding Head Tip Adjustment Unit

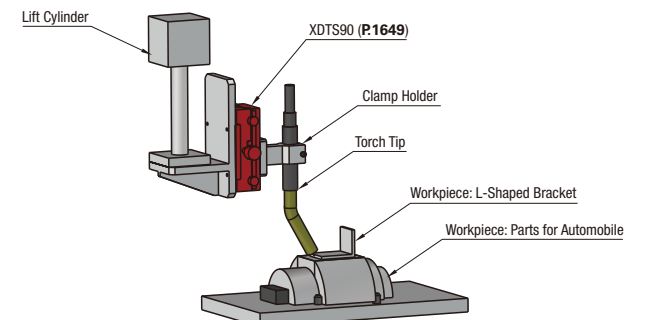

Secure Repeatability: Adjustment by a stage not by a clamp holder secures repeatability preventing misalignment of the torch.