

Bushings for Locating Pins –Standard– –Straight–



Bushings for Locating Pins are designed for light press fit O.D. tolerance and are not recommended to be used as drill bushings unless the mounting bore is adequately undersized. Used mainly in combination with locating pins, the bushings are very precise. Made out of O1 tool steel hardened to 60HRC.



U-JBAP

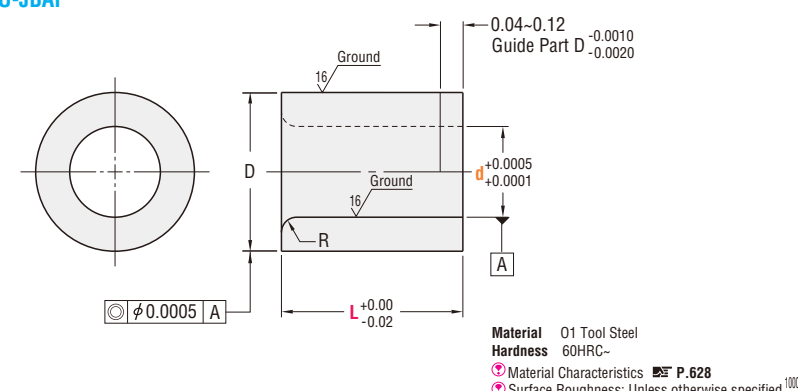

0.04~0.12 Guide Part D -0.0010
 -0.0020

d $+0.0005$
 $+0.0001$

L $+0.00$
 -0.02

Material O1 Tool Steel
Hardness 60HRC~
Material Characteristics **P.628**
Surface Roughness: Unless otherwise specified $100\sqrt{\text{ }}$

From	To	Tolerance
0.000	5.000	± 0.01
5.001	16.000	± 0.02
16.001	60.000	± 0.05

Ⓜ Thread or hole location tolerance: ± 0.005 non-cumulative.

Part No.	L Selection										R	D		\$ Unit Price	
	Type	d Callout	d Nominal	5/16	3/8	1/2	5/8	3/4	1"	1-1/4		Diameter	Tolerance		Qty. 1~29
U-JBAP	0.19	3/16	0.31	0.38	0.50	0.63					0.04	0.3750	0.3759	0.3756	6.10
	0.25	1/4	0.31	0.38	0.50	0.63	0.75				0.04	0.4375	0.4387	0.4382	5.70
	0.31	5/16	0.31	0.38	0.50	0.63	0.75				0.06	0.5000	0.5011	0.5007	5.70
	0.38	3/8		0.38	0.50	0.63	0.75	1.00			0.09	0.6250	0.6261	0.6257	6.10
	0.44	7/16			0.50	0.63	0.75	1.00	1.25		0.09	0.7500	0.7514	0.7509	7.00
	0.50	1/2			0.50	0.63	0.75	1.00	1.25		0.09	0.7500	0.7514	0.7509	7.90
	0.56	9/16			0.50	0.63	0.75	1.00	1.25		0.13	0.8750	0.8764	0.8759	8.80
	0.63	5/8			0.50	0.63	0.75	1.00	1.25		0.13	1.0000	1.0014	1.0009	8.80

Order Example Ⓜ The part number consists only of the fields with blue characters.

Part No. — **L**

Type **d**

U-JBAP 0.31 — L 0.50

Days to Ship **1** Day

Price

Quantity	1-29	30-49	50-99	100~
Rate	—	2%	3%	5%

Ⓜ For larger quantity orders "Days to Ship" may differ from published catalog term. **P.29**

Bushings for Locating Pins –Standard– –Flanged–



Bushings for Locating Pins are designed for light press fit O.D. tolerance and are not recommended to be used as drill bushings unless the mounting bore is adequately undersized. Used mainly in combination with locating pins, the bushings are very precise. Made out of O1 tool steel hardened to 60HRC.



U-JBHP

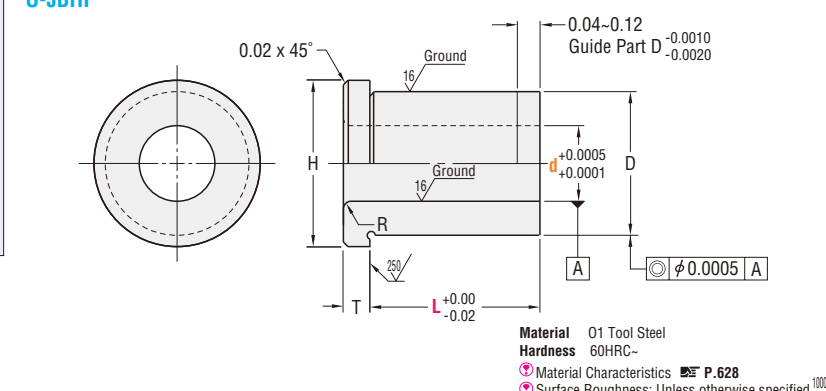

0.02 x 45°

0.04~0.12 Guide Part D -0.0010
 -0.0020

d $+0.0005$
 $+0.0001$

L $+0.00$
 -0.02

Material O1 Tool Steel
Hardness 60HRC~
Material Characteristics **P.628**
Surface Roughness: Unless otherwise specified $100\sqrt{\text{ }}$

From	To	Tolerance
0.000	5.000	± 0.01
5.001	16.000	± 0.02
16.001	60.000	± 0.05

Ⓜ Thread or hole location tolerance: ± 0.005 non-cumulative.

Part No.	L Selection										R	H	T	D		\$ Unit Price	
	Type	d Callout	d Nominal	5/16	3/8	1/2	5/8	3/4	1"	1-1/4				Diameter	Tolerance		Qty. 1~29
U-JBHP	0.19	3/16	0.31	0.38	0.50	0.63					0.04	0.50	0.09	0.3750	0.3759	0.3756	8.80
	0.25	1/4	0.31	0.38	0.50	0.63	0.75				0.04	0.56	0.09	0.4375	0.4387	0.4382	8.80
	0.31	5/16	0.31	0.38	0.50	0.63	0.75				0.06	0.61	0.22	0.5000	0.5011	0.5007	8.80
	0.38	3/8		0.38	0.50	0.63	0.75	1.00			0.09	0.80	0.22	0.6250	0.6261	0.6257	9.70
	0.44	7/16			0.50	0.63	0.75	1.00	1.25		0.09	0.92	0.22	0.7500	0.7514	0.7509	9.70
	0.50	1/2			0.50	0.63	0.75	1.00	1.25		0.09	0.92	0.22	0.7500	0.7514	0.7509	12.30
	0.56	9/16			0.50	0.63	0.75	1.00	1.25		0.13	1.11	0.25	0.8750	0.8764	0.8759	14.10
	0.63	5/8			0.50	0.63	0.75	1.00	1.25		0.13	1.23	0.31	1.0000	1.0014	1.0009	14.10

Order Example Ⓜ The part number consists only of the fields with blue characters.

Part No. — **L**

Type **d**

U-JBHP 0.56 — L 1.00

Days to Ship **1** Day

Price

Quantity	1-29	30-49	50-99	100~
Rate	—	2%	3%	5%

Ⓜ For larger quantity orders "Days to Ship" may differ from published catalog term. **P.29**

Related Components



Locating Pins
P.325



Locating Pins
P.329



Locating Pins
for Jigs & Fixtures
P.355



Locating Pins
for Jigs & Fixtures
P.357



Express Options
P.30



MISUMI
www.misumiusa.com E-mail: inquire@misumiusa.com

TEL.1-847-843-9105 FAX.1-847-843-9107 TOLL FREE TEL.1-800-681-7475 TOLL FREE FAX.1-800-681-7402

Contents

- How to Use the Catalog
- Linear Motion
- Linear Shafts
- Bushings
- Shaft Supports
- Shaft Collars
- Linear Guides
- Rotary Motion
- Rotary Shafts
- Bearings w/ Housings
- Pulleys Belts Couplings
- Locating Components
- Locating Pins & Bushings
- Locating Components
- General Components
- Pivot Pins Floating Joints
- Posts Device Stands Strut Clamps
- Angle Plates Gussets Welded Stands
- Washers Collars
- Manifolds
- Urethanes Rubbers
- Plates
- Misc.
- Technical Data
- Business Information
- Index