

Locating Pins –Small Spherical Head–

The Locating Pins in this section are provided in: Head O.D. Specifiable (0.0005" inc.), and Head / Height / Shank Length, all user specifiable groupings. Available in hardened A2 tool steel and 304 stainless steel. See modifications for more customized options.



Material	Hardness	Type	
		Configurable P Dimension Round	Diamond
A2 Tool Steel	60-63HRC	U-JPQSA	U-JPQSD
304 Stainless Steel	-	U-SJPQSA	U-SJPQSD

Material Characteristics P.628, 629

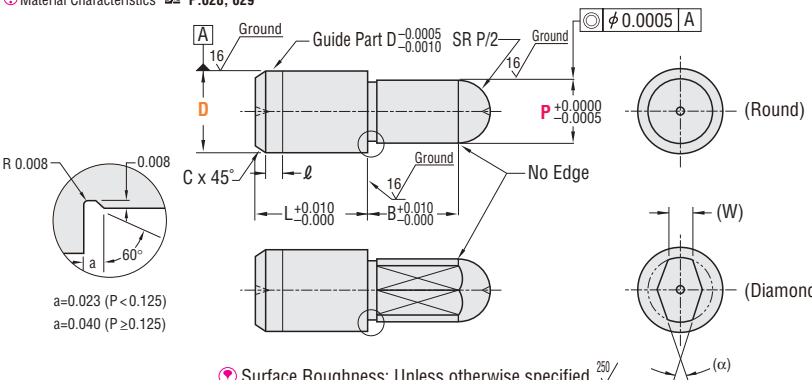

General Tolerance
Unless otherwise specified use the table below.

From	To	Tolerance
0.000	5.000	±0.01
5.001	16.000	±0.02
16.001	60.000	±0.05

Thread or hole location tolerance: ±0.005" non-cumulative.

Surface Roughness: Unless otherwise specified 250

Configurable P Dimension

Type	Part No.			Choose in 0.0005" Increments	L	B	C	l	(W)	(α)
	Callout	Nominal	Tolerance							
U-JPQSA U-JPQSD U-SJPQSA U-SJPQSD	0.13	1/8	0.1255 0.1252	0.0935 ~ 0.1250	0.188	0.125	0.02	0.06	-	60°
	0.19	3/16	0.1880 0.1877	0.1250 ~ 0.1875	0.375	0.188	0.05	0.06	0.047	60°
	0.25	1/4	0.2506 0.2502	0.1250 ~ 0.2500	0.375	0.188	0.05	0.06	0.047	60°
	0.31	5/16	0.3131 0.3127	0.1875 ~ 0.3125	0.594	0.250	0.06	0.06	0.078	60°
	0.38	3/8	0.3756 0.3752	0.2500 ~ 0.3750	0.594	0.313	0.08	0.06	0.094	60°
	0.50	1/2	0.5007 0.5003	0.2500 ~ 0.5000	0.875	0.313	0.08	0.08	0.125	60°

Order Example The part number consists only of the fields with blue characters.

Part No. — P —
Type D
U-JPQSA 0.25 — P 0.1875

Days to Ship 3 Days Non-Returnable P.30

Price

Quantity	Rate			
	1-4	5-19	20-49	50-150
Rate	—	5%	10%	15%

For larger quantity orders "Days to Ship" may differ from published catalog term. P.29

D	\$ Unit Price (Qty. 1-4)			
	Round		Diamond	
	U-JPQSA	U-SJPQSA	U-JPQSD	U-SJPQSD
0.13	6.90	9.30	-	-
0.19	8.20	11.10	11.50	15.20
0.25	8.60	11.60	12.30	17.10
0.31	9.00	12.20	12.70	17.90
0.38	9.50	12.80	13.30	18.70
0.50	10.30	14.00	14.50	20.60

Optional Modification Part No. — P — (Ordering Code)
Type D
U-JPQSA 0.25 — P 0.1875 — RC
6 Days Non-Returnable P.30

Optional Modification	Radius Modification
	RC (R0.02)
Ordering Code	RC
Detail	Increases structural strength against side impact. Example RC Changes the undercut on shank to R0.02 radius. Applicable for D-P ≥ 0.08
\$ Price Adder	3.00

When using Optional Modification, add the "Price Adder" to the standard "Unit Price".

Related Components

Material	Hardness	Type	
		Configurable P, L, B Dimension Round	Diamond
A2 Tool Steel	60-63HRC	U-FPQSA	U-FPQSD
304 Stainless Steel	-	U-SFPQSA	U-SFPQSD

Material Characteristics P.628, 629

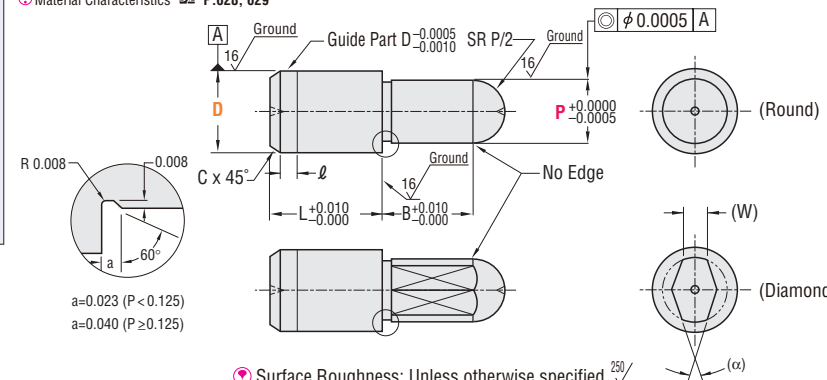

General Tolerance
Unless otherwise specified use the table below.

From	To	Tolerance
0.000	5.000	±0.01
5.001	16.000	±0.02
16.001	60.000	±0.05

Thread or hole location tolerance: ±0.005" non-cumulative.

Surface Roughness: Unless otherwise specified 250

Configurable P, L, B Dimension

Type	Part No.			Choose in 0.0005" Increments	Choose in 0.001" Increments	Choose in 0.001" Increments	C	l	(W)	(α)
	Callout	Nominal	Tolerance							
U-FPQSA U-FPQSD U-SFPQSA U-SFPQSD	0.13	1/8	0.1255 0.1252	0.0935 ~ 0.1250	0.125 ~ 0.250	0.094 ~ 0.375	0.020	0.06	-	60°
	0.19	3/16	0.1880 0.1877	0.1250 ~ 0.1875	0.188 ~ 0.375	0.094 ~ 0.375	0.050	0.06	0.047	60°
	0.25	1/4	0.2506 0.2502	0.1250 ~ 0.2500	0.250 ~ 0.500	0.094 ~ 0.500	0.050	0.06	0.047	60°
	0.31	5/16	0.3131 0.3127	0.1875 ~ 0.3125	0.313 ~ 0.625	0.094 ~ 0.594	0.063	0.06	0.078	60°
	0.38	3/8	0.3756 0.3752	0.2500 ~ 0.3750	0.375 ~ 0.750	0.125 ~ 0.750	0.080	0.06	0.094	60°
	0.50	1/2	0.5007 0.5003	0.2500 ~ 0.5000	0.500 ~ 1.000	0.188 ~ 0.750	0.080	0.08	0.125	60°

Order Example The part number consists only of the fields with blue characters.

Part No. — P — L — B —
Type D
U-FPQSA 0.25 — P 0.1875 — L 0.250 — B 0.250

Days to Ship 6 Days

Price

Quantity	Rate			
	1-4	5-19	20-49	50-150
Rate	—	5%	10%	15%

For larger quantity orders "Days to Ship" may differ from published catalog term. P.29

D	\$ Unit Price (Qty. 1-4)			
	Round		Diamond	
	U-FPQSA	U-SFPQSA	U-FPQSD	U-SFPQSD
0.13	8.10	12.10	-	-
0.19	9.70	14.40	13.00	19.80
0.25	10.10	15.10	13.80	20.90
0.31	10.60	15.90	14.30	22.00
0.38	11.10	16.60	15.00	22.90
0.50	12.10	18.10	16.30	25.10

Optional Modification Part No. — P — L — B — (Ordering Code)
Type D
U-FPQSA 0.25 — P 0.1875 — L 0.250 — B 0.250 — RC

Optional Modification	Radius Modification
	RC (R0.02)
Ordering Code	RC
Detail	Increases structural strength against side impact. Example RC Changes the undercut on shank to R0.02 radius. Applicable for D-P ≥ 0.08
\$ Price Adder	3.00

When using Optional Modification, add the "Price Adder" to the standard "Unit Price".

Express Options P.30

MISUMI www.misumiusa.com E-mail: inquire@misumiusa.com

TEL.1-847-843-9105 FAX.1-847-843-9107 TOLL FREE TEL.1-800-681-7475 TOLL FREE FAX.1-800-681-7402