

Bearings with Housings –Double Bearings, Direct Mount–



The Double Bearing Housing Units are intended for direct mounting on flat surfaces and will require external means of retaining the bearings, such as our shaft collars, locknuts or other suitable devices. (See pictures at the bottom of the next page for related component reference.) The bearings used are deep groove type.

Material	Surface Treatment	Type	
		Round	Square
1045 Steel	Electroless Nickel Plating	U-BGRC	U-BGSC
2017 Aluminum	Clear Anodizing	U-BARC	U-BASC
304 Stainless Steel	-	U-SBGR	U-SBGS

Material Characteristics P.628, 629

Bearing Tolerance: ABEC-1 ANSI/ABMA20-1987 P.274

Round

Square

General Tolerance Unless otherwise specified use the table below.

From	To	Tolerance
0.000	5.000	±0.01
5.001	16.000	±0.02
16.001	60.000	±0.05

Thread or hole location tolerance: ±0.005* non-cumulative.

Surface Roughness: Unless otherwise specified

Part No.	L Selection					d	D (H7)		B	H	T	dh	D1		P.C.D.	K	d2	d1	H1	Compatible Bolt				
	Type	Bearing No.	1"	1-1/4"	1-1/2"		2"	2-1/4"					mm	Inch							Dimension	Tolerance (in)		
Round U-BGRC U-BARC U-SBGR	6000ZZ	1.00	1.50			10	0.3937	26	1.0236	8	0.315	1.94	0.313	0.866	1.2500	1.2496	1.2487	1.563	1.50	0.180	0.313	0.180	#8	
	6001ZZ	1.00	1.50			12	0.4724	28	1.1024	8	0.315	2.06	0.313	0.945	1.3125	1.3121	1.3112	1.625	1.56	0.180	0.313	0.180	#8	
	6002ZZ		1.25	2.00			15	0.5906	32	1.2598	9	0.354	2.38	0.375	1.102	1.5000	1.4996	1.4987	1.875	1.81	0.206	0.375	0.206	#10
Square U-BGSC U-BASC U-SBGS	6003ZZ		1.50	2.00			17	0.6693	35	1.3780	10	0.394	2.56	0.375	1.220	1.6875	1.6871	1.6862	2.063	1.94	0.206	0.375	0.206	#10
	6004ZZ		1.50	2.00			20	0.7874	42	1.6535	12	0.472	2.94	0.438	1.417	1.8750	1.8746	1.8737	2.375	2.31	0.281	0.438	0.281	1/4
	6005ZZ		1.50	2.25			25	0.9843	47	1.8504	12	0.472	3.38	0.500	1.614	2.1250	2.1246	2.1234	2.750	2.63	0.344	0.531	0.344	5/16

Order Example The part number consists only of the fields with blue characters. The D (H7) is a standard fit representing clearance fit tolerance. P.608

Part No. -

Type Bearing No. -

Days to Ship Day

Price **Quantity Discount Rate**

Quantity	1-9	10-19	20-49	50~
Rate	-	2%	3%	5%

*For larger quantity orders "Days to Ship" may differ from published catalog term. P.29

Bearing No.	\$ Unit Price (Qty. 1~9)					
	Round			Square		
	U-BGRC	U-BARC	U-SBGR	U-BGSC	U-BASC	U-SBGS
6000ZZ	38.30	42.50	61.40	43.30	48.10	69.40
6001ZZ	39.40	45.60	63.90	44.50	51.40	72.30
6002ZZ	42.40	47.90	72.00	48.00	54.00	81.50
6003ZZ	47.10	55.10	91.60	54.30	61.40	103.50
6004ZZ	48.40	55.90	94.90	54.80	63.00	107.10
6005ZZ	49.50	-	-	56.10	-	-

Material	Surface Treatment	Type	
		Compact	Compact
1045 Steel	Electroless Nickel Plating	U-BGCC	U-BGCC
2017 Aluminum	Clear Anodizing	U-BACC	U-BACC
304 Stainless Steel	-	U-SBGCC	U-SBGCC

Material Characteristics P.628, 629

Bearing Tolerance: ABEC-1 ANSI/ABMA20-1987 P.274

d6-15

Compact

General Tolerance Unless otherwise specified use the table below.

From	To	Tolerance
0.000	5.000	±0.01
5.001	16.000	±0.02
16.001	60.000	±0.05

Thread or hole location tolerance: ±0.005* non-cumulative.

Surface Roughness: Unless otherwise specified

Part No.	L Selection					d	D (H7)		B	H	T	dh	D1		W	A	F	d2	d1	H1	Compatible Bolt				
	Type	Bearing No.	3/4"	1"	1-1/4"		1-1/2"	2"					2-1/4"	mm								Inch	Dimension	Tolerance (in)	
Compact U-BGCC U-BACC U-SBGCC	626ZZ	0.75	1.25			6	0.2362	19	0.7480	6	0.236	1.63	0.313	0.591	0.8750	0.8747	0.8739	0.94	1.250	-	0.180	0.313	0.180	#8	
	628ZZ		1.00	1.50			8	0.3150	24	0.9449	8	0.315	1.81	0.313	0.787	1.1250	1.1247	1.1239	1.25	1.438	-	0.180	0.313	0.180	#8
	6000ZZ		1.00	1.50			10	0.3937	26	1.0236	8	0.315	1.94	0.313	0.866	1.2500	1.2496	1.2487	1.31	1.563	-	0.180	0.313	0.180	#8
U-BGCC U-BACC U-SBGCC	6001ZZ		1.00	1.50			12	0.4724	28	1.1024	8	0.315	2.06	0.313	0.945	1.3125	1.3121	1.3112	1.38	1.625	-	0.180	0.313	0.180	#8
	6002ZZ		1.25	2.00			15	0.5906	32	1.2598	9	0.354	2.38	0.375	1.102	1.5000	1.4996	1.4987	1.63	1.875	-	0.206	0.375	0.206	#10
	6003ZZ		1.50	2.00			17	0.6693	35	1.3780	10	0.394	2.56	0.375	1.220	1.6875	1.6871	1.6862	1.75	1.750	1.125	0.206	0.375	0.206	#10
U-BGCC U-BACC U-SBGCC	6004ZZ		1.50	2.00			20	0.7874	42	1.6535	12	0.472	2.94	0.438	1.417	1.8750	1.8746	1.8737	2.00	2.125	1.188	0.281	0.438	0.281	1/4
	6005ZZ		1.50	2.25			25	0.9843	47	1.8504	12	0.472	3.38	0.500	1.614	2.1250	2.1246	2.1234	2.25	2.375	1.375	0.344	0.531	0.344	5/16

Order Example The part number consists only of the fields with blue characters. The D (H7) is a standard fit representing clearance fit tolerance. P.608

Part No. -

Type Bearing No. -

Days to Ship Day

Price **Quantity Discount Rate**

Quantity	1-9	10-19	20-49	50~
Rate	-	2%	3%	5%

*For larger quantity orders "Days to Ship" may differ from published catalog term. P.29

Bearing No.	\$ Unit Price (Qty. 1~9)		
	Compact		
	U-BGCC	U-BACC	U-SBGCC
626ZZ	38.30	41.90	62.30
628ZZ	40.10	45.80	65.10
6000ZZ	41.50	46.30	66.80
6001ZZ	42.80	49.50	69.40
6002ZZ	46.10	52.00	78.30
6003ZZ	50.90	59.10	101.80
6004ZZ	52.50	60.60	103.00
6005ZZ	54.00	-	-

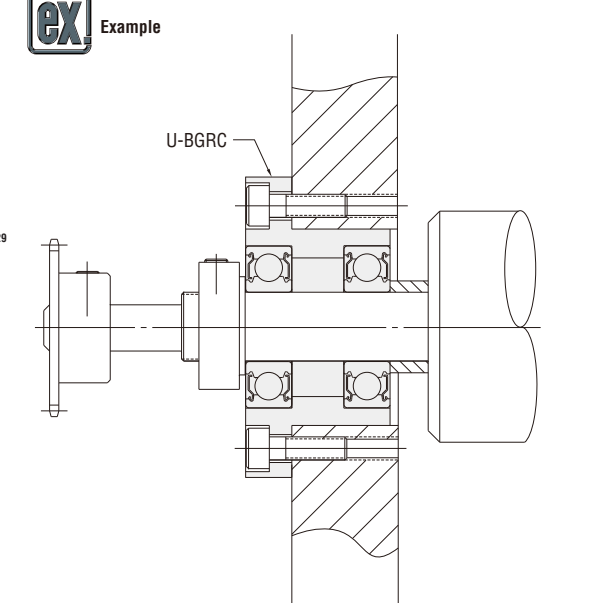

Related Components

- Rotary Shafts P.205
- Bearing Locknuts P.275
- Bearing Spacers P.277

Express Options P.30

MISUMI www.misumiusa.com E-mail: inquire@misumiusa.com

TEL.1-847-843-9105 FAX.1-847-843-9107 TOLL FREE TEL.1-800-681-7475 TOLL FREE FAX.1-800-681-7402

- Contents
- How to Use the Catalog
- Linear Motion
- Linear Shafts
- Bushings
- Shaft Supports
- Shaft Collars
- Linear Guides
- Rotary Motion
- Rotary Shafts
- Bearings w/ Housings
- Pulleys Belts Couplings
- Locating Components
- Locating Pins & Bushings
- Locating Components
- General Components
- Pivot Pins Floating Joints
- Posts Device Stands Strut Clamps
- Angle Plates Gussets Welded Stands
- Washers Collars
- Manifolds
- Urethanes Rubbers
- Plates
- Misc.
- Technical Data
- Business Information
- Index